



CATALOGUE 2023

Product overview
on page 4 - 5

Professional
diamond tools & machines

www.samedia.com



FASTER • STRONGER • SAFER

Dear Business Partner,

We are delighted to present the SAMEDIA product catalogue 2023.

Discover our new diamond tools and machines for the professional cutting, drilling and grinding of construction and other mineral materials in wet and dry applications.

You will notice our new dynamic SHOXX design when browsing.

We developed this to highlight the exceptional performance and user safety of SHOXX products.

Our high-quality tools cut twice as fast when compared to most professional competitor products, and are characterised by an extremely long service life, while the welded segments are held in place by the steel core for maximum safety.

This is made possible by the unique, globally patented forging technology used in our production facility in Germany.

When looking to benefit from an unsurpassed level of performance on the market, demand SHOXX quality, now featuring a unique design and the original SHOXX logo segment, as a seal of quality.

As co-founders of SEAM, we strive to improve around the globe, in order to realise a cleaner environment, more socially respectful management and a more sustainable business model.

We hope you enjoy reading, and feel free to get in touch with us 24/7 at www.samedia.com.

We will be happy to meet even your most demanding needs!

With kind regards;

Nicolas Vermeulen
(Managing Director SAMEDIA)

Learn more about SEAM at www.seam.earth, #WeAreSeam.



Discover more about SAMEDIA on our website www.samedia.com
and on our social media channels.



NEW
SHOXX-DESIGN
 from page. 16

VISIT US ONLINE



CONTENT







	page
CONTENT	4-5
COMPANY	6-7
SHOXX TECHNOLOGY	8-9
SYMBOLS	10-11
QUALITY & SAFETY	12
SUBSCRIPT	154
CONDITIONS	163

SAMEDIA DIAMOND TOOLS





from page 13





CUTTING

	FOR ANGLE GRINDERS	● ● ● ○ ●	page 14
	FOR CUT-OFF PETROL SAWS	● ● ● ●	page 38
	FOR TABLE SAWS	● ● ● ○ ●	page 47
	FOR TILE CUTTERS	● ● ● ○ ●	page 47
	FOR FLOOR SAWS	● ● ● ●	page 58
	FOR WALL CHASER	● ●	page 64
	FOR WALL SAWS	●	page 68

CORING/DRILLING

	FOR CORING MACHINES	● ●	page 72
	FOR DRILLING MACHINES (SOCKET SINKER)	●	page 78
	FOR ANGLE GRINDERS	○	page 81
	FOR DRILLING MACHINES/CORDLESS SCREWDRIVERS	○	page 84

GRINDING

	FOR GRINDING MACHINES FREEHAND	● ● ● ● ●	page 88
	FOR FLOOR GRINDERS	●	page 95
	FOR ANGLE GRINDERS	○ ●	page 98

● CONCRETE
 ● UNIVERSAL
 ● GRANITE
 ○ TILES
 ● ASPHALT
 ● SPECIAL







SAMEDIA MACHINES

from page 101

CUTTING

	ANGLE GRINDERS	page 102
	ELECTRIC CUT-OFF SAW	page 103
	TABLE SAWS	page 104
	TILE CUTTERS	page 117
	FLOOR SAWS	page 120

CORING/DRILLING

	CORING SYSTEMS	page 122
	CORING MACHINES FREEHAND	page 129
	CORING MACHINES WITH STAND	page 131
	DRILLING MACHINES (SOCKET SINKER)	page 138

GRINDING

	GRINDING MACHINES FREEHAND	page 140
	FLOOR GRINDER	page 146

VACUUMING

	INDUSTRIAL VACUUM CLEANER	page 150
---	----------------------------------	----------



SAMEDIA Branch and Production Site, Denzlingen/Germany

MANUFACTURER

As part of the JFC Group, SAMEDIA is one of the world's most powerful manufacturers of professional diamond tools. As a member of  (Organisation for the Safety of Abrasive Tools), high standards of product safety are at the forefront of SAMEDIA.

The majority of the laser-welded diamond cutting blades, grinding cup wheels and diamond core bits are produced in Germany. SAMEDIA is using a unique worldwide patented hot forging technology called SHOXX® for the production of segments.



NETWORK

The corporate network's production sites are distributed across central Europe. Since 2016 belongs a manufacturer of professional table saw machines to the group of companies.

Through the interlinking of diamond tools and machinery, we are in a position to produce perfectly matching systems. As a result, professional craftsmen are offered genuine solutions for the areas of cutting, coring and grinding from a single source.

1 GERMANY
SAMEDIA GMBH
 Marie-Curie-Straße 10
 D-79211 Denzlingen
 Tel +497666-9326 0
 Fax +497666-9326 900
 verkauf@samedia.com

2 FRANCE

3 BELGIUM

4 SWITZERLAND



CONTACT

● **SAMEDIA GMBH**
 Marie-Curie-Straße 10
 D-79211 Denzlingen
 Tel +49 7666-93260
 Fax +49 7666-9326900
 verkauf@samedia.com

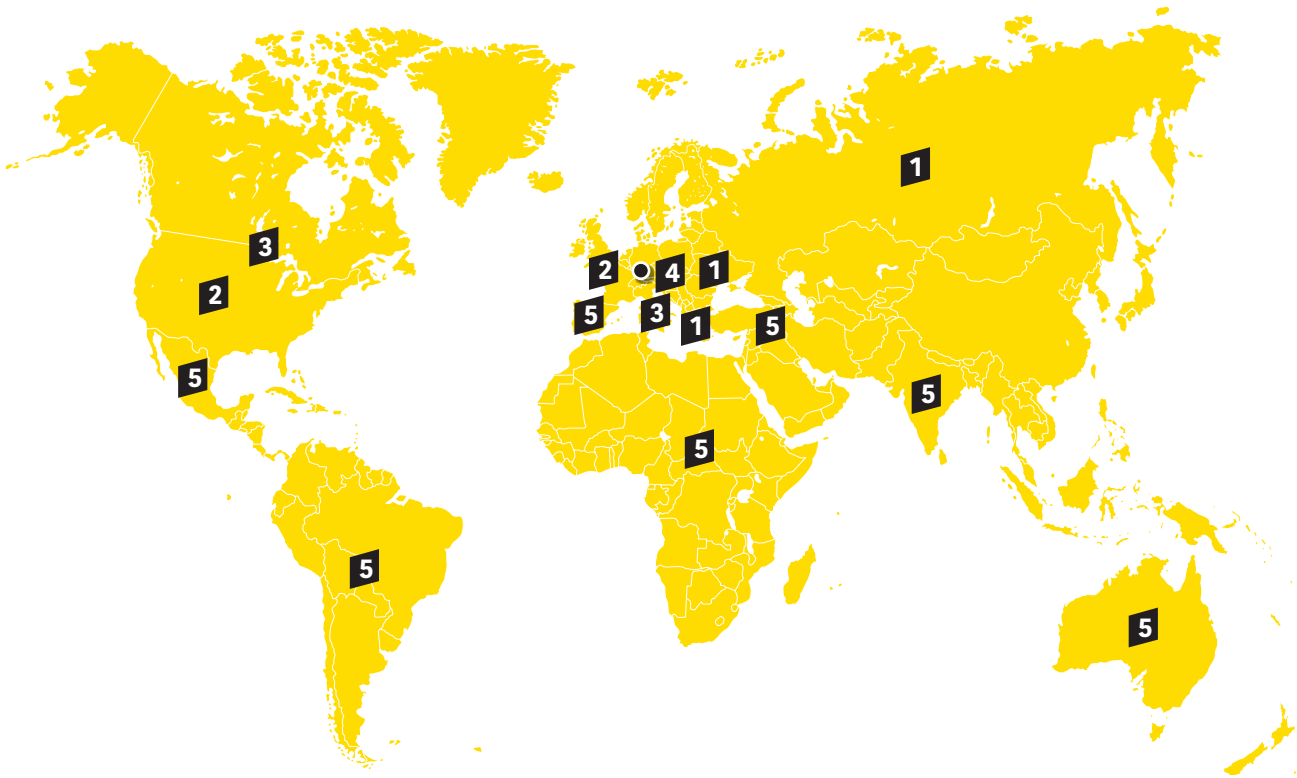

CONSULTING & SALES

1 Adrian Popescu
 Export Director
 Central Eastern Europe
 Tel +373 79 45 44 15, +40 720 170 614
 adrian.popescu@samedia.com

3 Enrico Mariotti
 Export Sales Director
 USA/Canada/Italy
 Tel. +32 478 42 32 35
 erico.mariotti@samedia.com

5 Davut Akcayir
 Export Director
 South Europe/America/MEA
 Tel. +33 681 824 617
 davut.akcayir@samedia.com

2 Cedric Sauret
 Export Director
 North West Europe/USA
 Tel +33 (0)631 430385
 cedric.sauret@samedia.com

4 Piotr Różyło
 Business Development Director
 PL/CZ/SK
 Tel. +48 512 265 625
 piotr.rozylo@samedia.com



SHOXX®-TECHNOLOGY

The development of SHOXX-Technology has succeeded in revolutionising the standard process that has been known up until now for segment production. SHOXX process is based on a forging technology which was developed within our group, and is implemented through our production technology. Therefore, with an highly automated production, our expertise enables the use of new SHOXX segments for a cutting capacity that has been unachievable up until now.



Our know-how enables a highly automated production process which permits the use of new segment recipes to obtain unattainable cutting performance.

This new manufacturing process in connection with new recipes allows the user a **FASTER • STRONGER • SAFER** work with our tools.

SHOXX cutting discs stand out in terms of cutting speed, tool life and universality compare to conventional cutting discs. Thanks to their properties, they are particularly suited for intensive continuous operation.

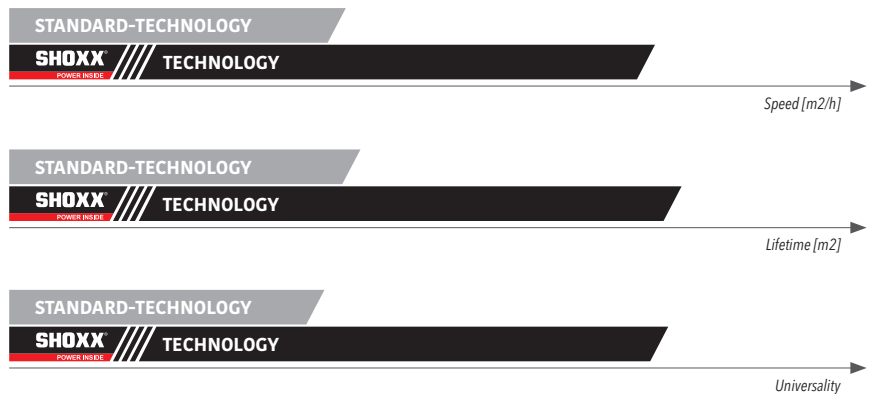

With regard to cutting speed, lifetime and versatility, SHOXX blade clearly distinguish themselves from conventional cutting discs. Thanks to their properties, they are particularly suited for intensive continuous operation.

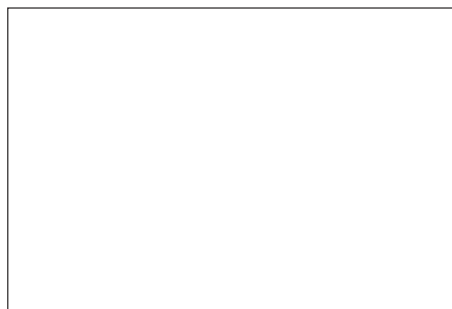

REDUCED VIBRATION THANKS TO **SHOXX**[®]

Due to the special segment geometry, the SHOXX cutting discs achieve a significantly reduced vibration stress. This results in fewer work breaks. In opposite to standard methods, the SHOXX technology also permits the production of higher segments (until 20mm).

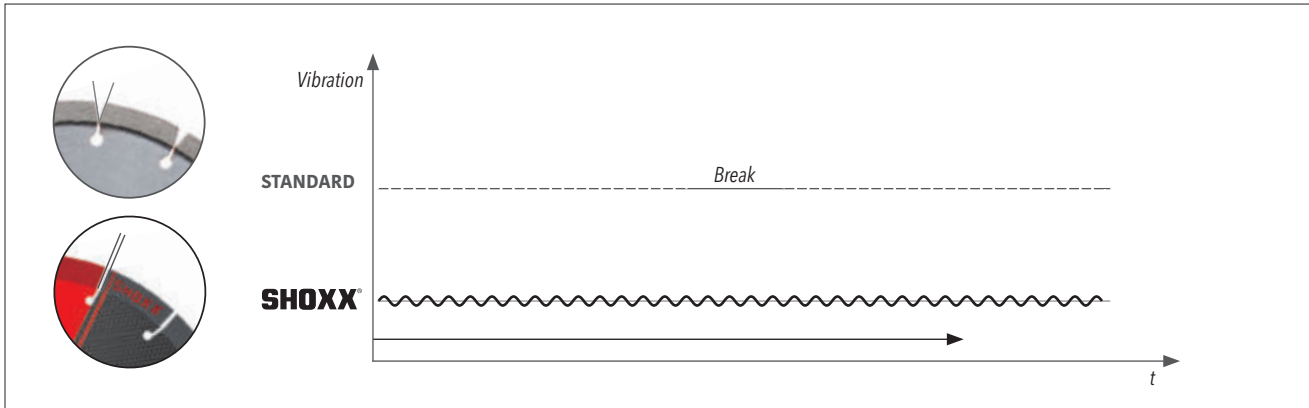

Reduced vibration thanks to the **SHOXX**[®] technology

MORE SECURITY THROUGH **SHOXX**[®]

Another fundamental benefit is the safety. Due to the dense pore-free segments, welding properties with incomparably high safety against segment break-off results compared to the usual standard sintering technology.

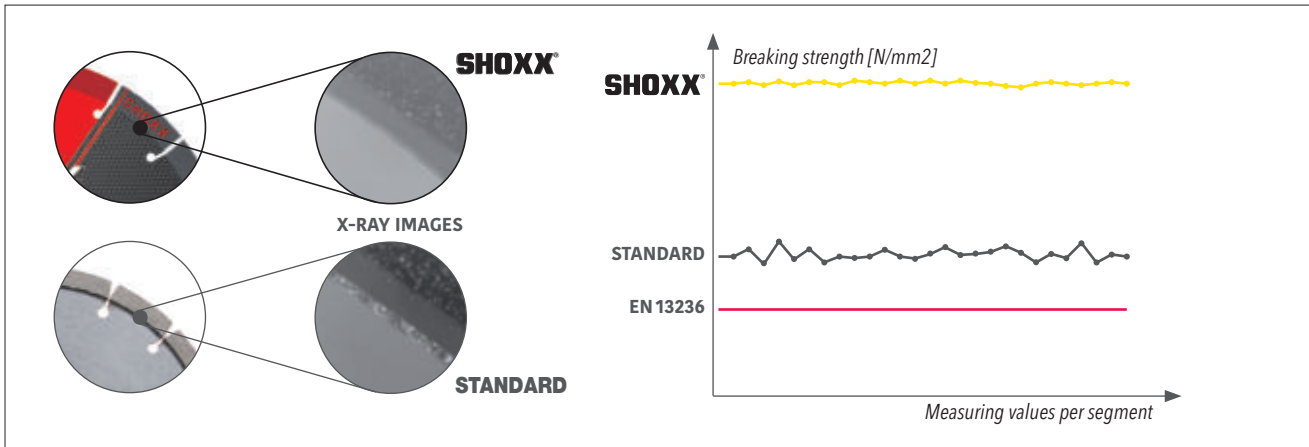

Deep and porefree welding of the **SHOXX**[®] segments

SHOXX[®]-BENEFITS AT A GLANCE

- Intensive continuous operation
- Speed
- Lifetime
- Universality
- Safety

SYMBOLS

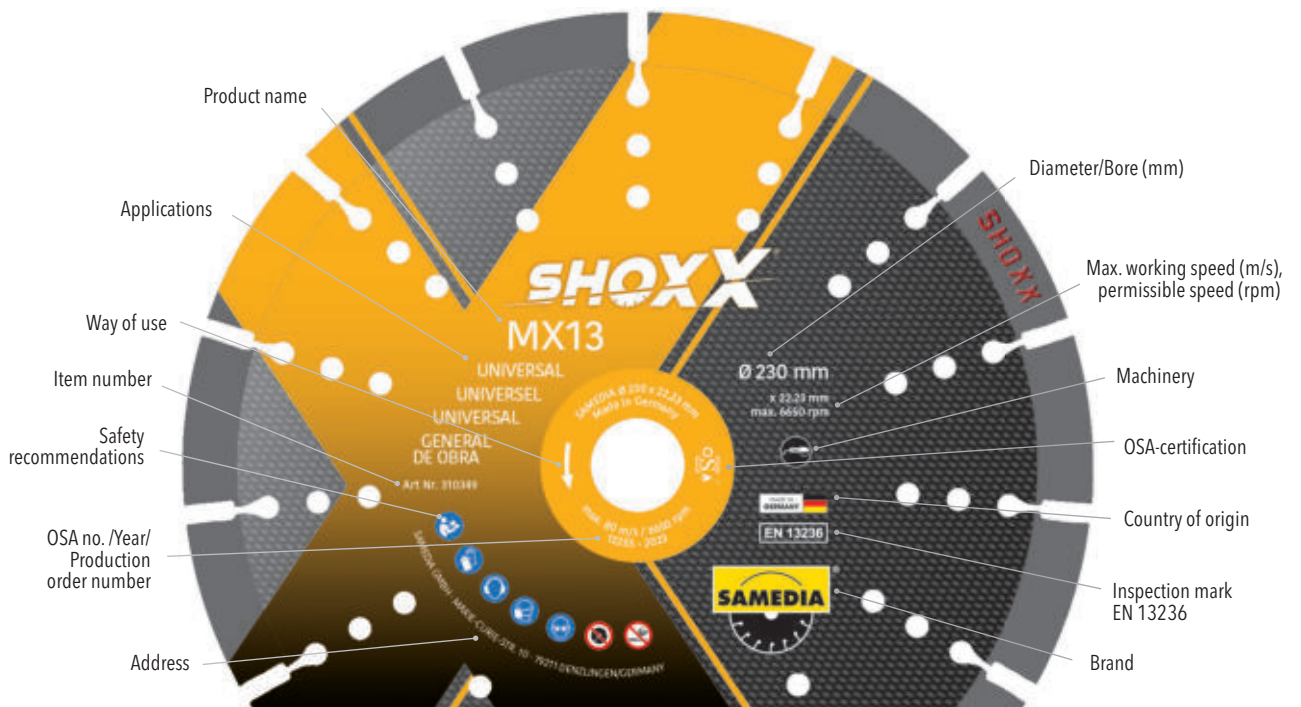

OUR QUALITY LEVELS

Our product range is divided into 4 categories. The product lines differ as follows:



HighEnd tools for intensive use with maximum versatility, cutting speed and life time.



Premium quality for high requirements.



Professional tools with optimum price-performance ratio.

SOLID



Standard diamond tools.

COLOR CODE APPLICATION

CONCRETE

UNIVERSAL

GRANITE

TILES

ASPHALT

SPECIAL

MACHINES' SYMBOLS

ANGLE GRINDER

CUT-OFF PETROL SAW

TABLE SAW

TILE CUTTER

WALL CHASER

WALLSAW

FLOOR SAW

INDUSTRIAL VACUUM CLEANER

DRILLING MACHINE (SOCKET SINKER)

DRILLING MACHINE

CORING SYSTEM

CORING MACHINE FREEHAND

CORING MACHINE WITH STAND

GRINDING MACHINE FREEHAND

FLOOR GRINDER

SYMBOL

WET CUT

With a few exceptions, our tools are suitable for performing dry and wet cuts. We have marked those tools only suitable for wet cuts with the following symbol:



ICONS

The following markings (icons) can be found on our tools:

Read the operating instructions

Wear protective gloves

Wear ear protection

Wear a protective mask

Wear safety glasses

Do not use damaged tools

Do not use to grind

APPLICATION RECOMMENDATION

In our catalog we have divided the recommended use of our tools into two categories:

- ✓✓ IDEALLY SUITED**
- ✓ WELL SUITED**

PRODUCT SAFETY

Our internal quality management system, certified according to ISO 9001:2008, starts with the careful choice of raw materials.

We only purchase base materials such as diamonds and steel cores from long-standing suppliers who know how to satisfy our requirements.

As a member of OSA[®] (Organisation for the Safety of Abrasives), we manufacture in accordance with the directives of EN 13236 (European safety standard for diamond tools) and are a member of the VDS (German Abrasives Association).



EN 13236 CONFORM

Our manufacturing process guarantees the conformity of tools according to EN 13236 to ensure safe use.

OSA CERTIFIED



The OSA[®] guarantees compliance with EN 13236.

OSA[®]: Organization for the safety of abrasives. The largest manufacturer of abrasive products has joined forces in this international organization to set safety standards for their products. The aim is to keep the quality of their products at a very high level, in the interest of abrasives users.

SAMEDIA has been a member of the OSA[®] since 2004.

For more information, see www.osa-abrasives.org

SAMEDIA is an active member of:



SAMEDIA IS A FOUNDING MEMBER OF SEAM!

Sustainable European Abrasive Manufacturers

All SEAM members commit to making their entire abrasives production process sustainable in terms of the environment, working conditions and all economic issues. www.seam.earth, #WeAreSeam.





CUTTING

RECOMMENDATION TABLE ANGLE GRINDER

MATERIAL	CONCRETE						UNIVERSAL									GRANITE				
	UX17	RX13	BX13	BGM	BSE	BCS	MY13	MST	MTT	MSE	MES	MSS	MTS	TPM	TPT	CX13 SILENCIO*	CX13	GSM SILENCIO*	CTM	TSM
	SHOXX	MASTER			SOLID	SHOXX	MASTER		TECHNIC		SOLID		MASTER	TECHNIC	SHOXX	MASTER		MASTER		
segment height	17	13	13	13	10	10	13	11	10	12	10	8	7	9	10	13	13	11	10	9
diameter (mm)	230	115-230	115-230	115-230	115-230	115-230	115-230	115-230	115-230	115-230	115-230	105-230	115-230	115-125	115-125	230	230	125-230	115-230	125-230
XLOCK			X					X												
page	16	17	17	18	18	19	20	21	21	22	22	22	23	23	23	24	25	25	26	26
reinforced concrete	✓✓	✓✓	✓✓	✓✓	✓		✓✓	✓								✓	✓	✓		
washed concrete	✓✓	✓✓	✓✓	✓	✓		✓	✓								✓	✓	✓		
concrete/concrete products	✓✓	✓✓	✓✓	✓✓	✓✓	✓	✓✓	✓✓	✓✓	✓✓	✓	✓	✓			✓✓	✓✓	✓	✓	✓
extreme dense sand-lime brick		✓✓																		
brickwork/bricks	✓✓	✓✓	✓✓	✓✓	✓✓	✓	✓✓	✓✓	✓✓	✓	✓	✓	✓			✓	✓	✓	✓	
roof tiles	✓✓	✓✓	✓✓	✓✓	✓✓	✓	✓✓	✓✓	✓✓	✓	✓					✓	✓✓		✓✓	
sand-lime brick	✓✓	✓	✓	✓	✓	✓	✓✓	✓	✓	✓✓				✓✓	✓					
sandstone	✓✓	✓	✓	✓	✓		✓✓	✓		✓										
screed	✓						✓✓													
asphalt	✓						✓													
hard cement joints														✓✓	✓					
abrasive cement joints														✓✓	✓					
shell limestone														✓✓	✓					
quartz																✓	✓		✓	✓
granite/natural stone	✓		✓✓	✓	✓											✓✓	✓✓	✓	✓	✓✓
limestone/travertine																✓	✓	✓	✓	✓
porphyry																✓✓	✓✓	✓	✓	✓
porcelain stoneware																				
tiles																				
glazed stove tiles																				
artificial stone/marble																				
hard bricks																				
slate																				
metal/steel	✓	✓																		
stainless steel																				
ductile iron pipes	✓	✓																		
PVC-/KG-/HT-pipes																				
PP-/PE-/PVC-pipes																				
plastic/GfK																				
timber/laminate																				
glass/fibre-glass																				

In addition to the suitability of the material, the products also differ in tool life and cutting speed. You can find more information on page 10.



CUTTING

PORCELAIN STONEWARE/TILES											SPECIAL													
CKM	K7X	KVX	KTM	KCM	KJM	KTT	KCT	TCS	KCS	KX13 SILENCIO*	KY13	TX13	VFM	PVM	RFS	UVM	UTM	HLK	UGM	TKE	TKM	SMT	CAV	
MASTER	SHOXX	MASTER				TECHNIC		SOLID		SHOXX			MASTER										TECHNIC	
8	10	8	10	7	7	10	7	8	6	13	13	13	12	3	3	3	2	1	3					3
125-180	115-125	115-230	115-230	115-230	115-230	115-125	115-230	115	115-230	230	230	230	125-230	125	125-230	115-230	115-230	115-230	125-230	115-230	115-230	115-230	115-125	115-230
			X	X																				
26	27	28	28	29	29	30	30	30	31	32	33	33	33	34	34	34	35	35	35	36	36	37	37	
										✓	✓	✓✓	✓✓											
✓										✓	✓	✓✓	✓✓			✓			✓					
																✓								
✓																✓								
													✓✓											
													✓✓											
													✓✓	✓✓										
													✓✓	✓✓										
✓	✓✓	✓	✓✓	✓	✓✓															✓				
	✓	✓	✓	✓	✓																			
	✓✓	✓✓	✓✓	✓✓	✓✓	✓																		
	✓✓	✓✓	✓✓	✓✓	✓✓	✓✓	✓✓	✓	✓												✓✓			
	✓✓	✓✓	✓✓	✓✓	✓✓																			
	✓✓	✓	✓✓	✓	✓✓															✓✓				✓✓
										✓✓	✓✓													
										✓	✓													
	✓	✓	✓	✓	✓											✓	✓✓		✓	✓✓	✓✓	✓✓		
														✓✓		✓✓	✓✓							
														✓✓		✓✓	✓	✓✓						
														✓✓	✓✓	✓✓	✓	✓✓	✓✓					✓✓
																✓		✓✓						
																			✓✓					✓✓

* SILENCIO = significant noise reduction of approx. 80% compared to the standard steel core.

SHOXX
POWER INSIDE

UX17 ◆◆◆◆◆

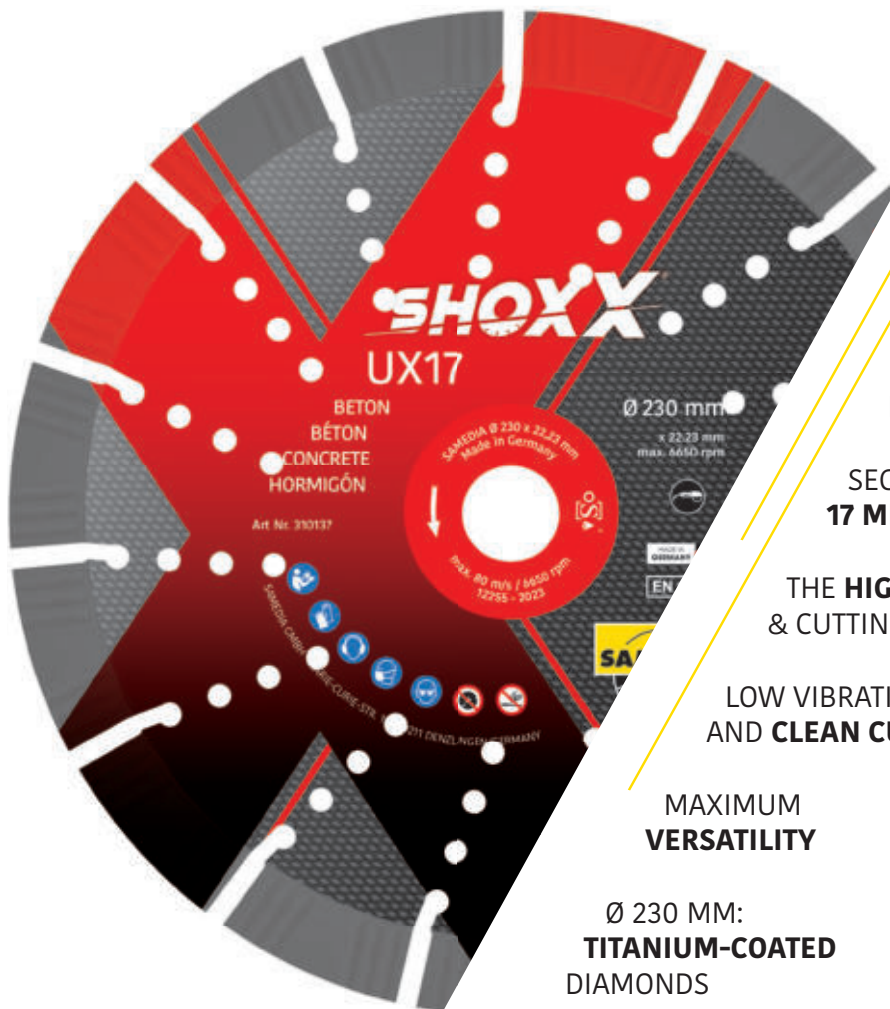

HIGH-END-DIAMOND BLADE

WITH **SHOXX** FORGED SEGMENTS

SEGMENT HEIGHT: **17 MM**

THE **HIGHEST LIFE TIME** & CUTTING PROPERTIES

LOW VIBRATION AND **CLEAN CUT**

MAXIMUM **VERSATILITY**

Ø 230 MM: **TITANIUM-COATED DIAMONDS**



More information

MADE IN GERMANY LASER WELDED EN 13236 compliant

MATERIAL

reinforced concrete	✓✓	roof tiles	✓✓	granite/natural stone	✓
washed concrete	✓✓	sand-lime brick	✓✓	ductile iron pipes	✓
concrete/concrete products	✓✓	sandstone	✓✓	metal/steel	✓
brickwork/bricks	✓✓	screed	✓	asphalt	✓

ITEM NUMBER	DESCRIPTION	Ø (MM)	BORE (MM)	NUMBER OF SEGMENTS	SEGMENT THICKNESS (MM)	LIST PRICE RRP (WITHOUT VAT IN EUR)
310137	UX17	230	22,23	15	2,8	



CUTTING

CONCRETE



RX13



EN 13236 compliant

MADE IN GERMANY

LASER WELDED

ADVANTAGES

- High-End-diamond blade with SHOXX forged segments
- segment height: 13 mm
- maximum cutting speed
- clean cut

MATERIAL

reinforced concrete	✓✓	sand-lime brick	✓
washed concrete	✓✓	sandstone	✓
concrete/concrete products	✓✓	ductile iron pipes	✓
extreme dense sand-lime brick	✓✓	metal/steel	✓
brickwork/bricks	✓✓		
roof tiles	✓✓		

ITEM NUMBER	DESCRIPTION	Ø (MM)	BORE (MM)	NUMBER OF SEGMENTS	SEGMENT THICKNESS (MM)	LIST PRICE RRP (WITHOUT VAT IN EUR)
310618	RX13	115	22,23	8	2,4	
310574	RX13	125	22,23	9	2,4	
310619	RX13	150	22,23	11	2,4	
310620	RX13	180	22,23	13	2,4	
310508	RX13	230	22,23	15	2,6	



BX13



ADVANTAGES

- High-End-diamond blade with SHOXX forged segments
- segment height: 13 mm
- the highest life time & cutting properties
- low vibration and clean cut

MATERIAL

reinforced concrete	✓✓	brickwork/bricks	✓✓
washed concrete	✓✓	roof tiles	✓✓
concrete/concrete products	✓✓	sand-lime brick	✓
granite/natural stone	✓✓	sandstone	✓

ITEM NUMBER	DESCRIPTION	Ø (MM)	BORE (MM)	NUMBER OF SEGMENTS	SEGMENT THICKNESS (MM)	LIST PRICE RRP (WITHOUT VAT IN EUR)
310064	BX13	115	22,23	8	2,4	
310058	BX13	125	22,23	9	2,4	
311582	BX13 XLOCK	125	XLOCK	9	2,4	
310522	BX13	140	22,23	10	2,4	
310625	BX13	150	22,23	11	2,4	
310609	BX13	180	22,23	13	2,4	
310044	BX13	230	22,23	15	2,6	
311704	BX13 COMFORT	230	22,23	15	2,6	

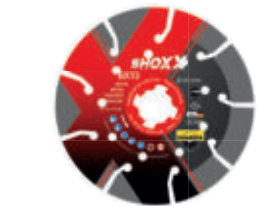

XLOCK



BX13 COMFORT
Reduced noise!

EN 13236 compliant

MADE IN GERMANY

LASER WELDED

MASTER // BGM



 **EN 13236**
compliant

MADE IN GERMANY 

LASER WELDED 

ADVANTAGES

- Premium diamond blade
- segment height: 13 mm
- high life time & cut quality
- low vibration

MATERIAL

reinforced concrete	✓✓	washed concrete	✓
concrete/concrete products	✓✓	sand-lime brick	✓
brickwork/bricks	✓✓	sandstone	✓
roof tiles	✓✓	granite/natural stone	✓

ITEM NUMBER	DESCRIPTION	Ø (MM)	BORE (MM)	NUMBER OF SEGMENTS	SEGMENT THICKNESS (MM)	LIST PRICE RRP (WITHOUT VAT IN EUR)
310830	BGM	115	22,23	8	2,4	
310538	BGM	125	22,23	9	2,4	
311066	BGM	150	22,23	11	2,6	
310539	BGM	230	22,23	15	2,6	

MASTER // BSE



 **EN 13236**
compliant

MADE IN GERMANY FROM Ø230 

LASER WELDED 

ADVANTAGES

- Premium diamond blade
- segment height: 10 mm

MATERIAL

concrete/concrete products	✓✓	washed concrete	✓
brickwork/bricks	✓✓	sand-lime brick	✓
roof tiles	✓✓	sandstone	✓
reinforced concrete	✓	granite / natural stone	✓

ITEM NUMBER	DESCRIPTION	Ø (MM)	BORE (MM)	NUMBER OF SEGMENTS	SEGMENT THICKNESS (MM)	LIST PRICE RRP (WITHOUT VAT IN EUR)
310365	BSE	115	22,23	8	2,2	
310024	BSE	125	22,23	9	2,2	
310366	BSE	150	22,23	10	2,3	
310367	BSE	180	22,23	14	2,6	
310025	BSE	230	22,23	15	2,6	

SOLID**BCS** 

EN 13236
compliant

ADVANTAGES

- Standard diamond blade
- segment height: 10 mm
- sintered segments
- Turbo segments

MATERIAL

concrete/concrete products	✓	roof tiles	✓
brickwork/bricks	✓	sand-lime brick	✓

ITEM NUMBER	DESCRIPTION	Ø (MM)	BORE (MM)	NUMBER OF SEGMENTS	SEGMENT THICKNESS (MM)	LIST PRICE RRP (WITHOUT VAT IN EUR)
310989	BCS	115	22,23	8	2,4	
310990	BCS	125	22,23	9	2,4	
310991	BCS	180	22,23	13	2,8	
310992	BCS	230	22,23	18	3,0	

**CUTTING****CONCRETE**

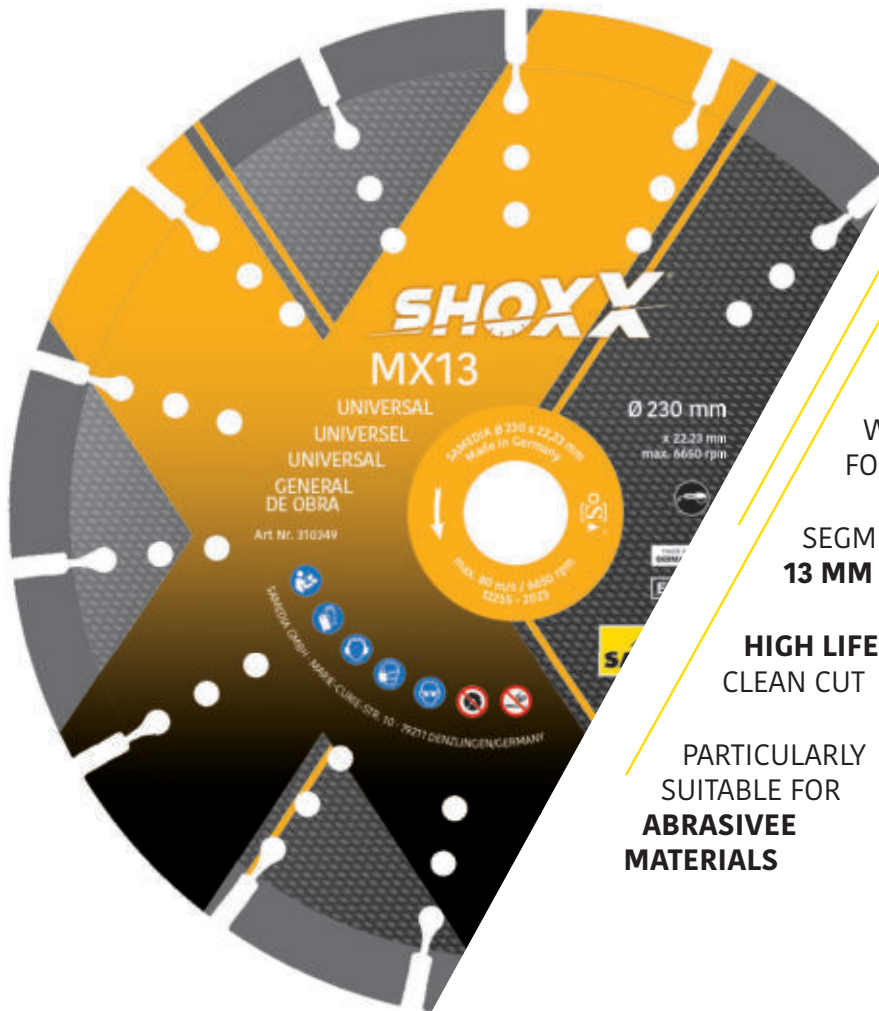

**HIGH-END-
DIAMOND BLADE**

WITH **SHOXX**
FORGED SEGMENTS

SEGMENT HEIGHT:
13 MM

**HIGH LIFE TIME &
CLEAN CUT**

PARTICULARLY
SUITABLE FOR
**ABRASIVE
MATERIALS**



More information



ITEM NUMBER	DESCRIPTION	Ø (MM)	BORE (MM)	NUMBER OF SEGMENTS	SEGMENT THICKNESS (MM)	LIST PRICE RRP (WITHOUT VAT IN EUR)
310345	MX13	115	22,23	8	2,4	
310346	MX13	125	22,23	9	2,6	
310617	MX13	140	22,23	10	2,6	
310347	MX13	150	22,23	11	2,6	
310348	MX13	180	22,23	13	2,4	
310349	MX13	230	22,23	16	2,6	

MATERIAL

reinforced concrete	✓✓
concrete/concrete products	✓✓
brickwork/bricks	✓✓
roof tiles	✓✓
sand-lime brick	✓✓
sandstone	✓✓
screed	✓✓
washed concrete	✓
asphalt	✓



CUTTING

UNIVERSAL

MASTER // MST



XLOCK

 EN 13236 compliant

MADE IN GERMANY 

LASER WELDED 

ADVANTAGES

- Premium diamond blade
- segment height: 11 mm
- universal range of applications

MATERIAL

concrete/concrete products	✓✓	washed concrete	✓
brickwork/bricks	✓✓	sand-lime brick	✓
roof tiles	✓✓	sandstone	✓
reinforced concrete	✓		

ITEM NUMBER	DESCRIPTION	Ø (MM)	BORE (MM)	NUMBER OF SEGMENTS	SEGMENT THICKNESS (MM)	LIST PRICE RRP (WITHOUT VAT IN EUR)
300009	MST	115	22,23	7	2,4	
300055	MST	125	22,23	8	2,4	
311583	MST XLOCK	125	XLOCK	8	2,4	
310045	MST	150	22,23	11	2,4	
310368	MST	180	22,23	12	2,4	
310783	MST	200	22,23	12	2,6	
300010	MST	230	22,23	15	2,6	

MASTER // MTT



 EN 13236 compliant

ADVANTAGES

- Premium diamond blade
- segment height: 10 mm
- continuous turbo rim

MATERIAL

concrete/concrete products	✓✓	roof tiles	✓✓
brickwork/bricks	✓✓	sand-lime brick	✓

ITEM NUMBER	DESCRIPTION	Ø (MM)	BORE (MM)	NUMBER OF SEGMENTS	SEGMENT THICKNESS (MM)	LIST PRICE RRP (WITHOUT VAT IN EUR)
300092	MTT	115	22,23	1	2,2	
300011	MTT	125	22,23	1	2,2	
310046	MTT	150	22,23	1	2,2	
311059	MTT	180	22,23	1	2,6	
300056	MTT	230	22,23	1	2,6	

TECHNIC

MSE



EN 13236 compliant

ADVANTAGES

- Professional diamond blade
- segment height: 12 mm

MATERIAL

concrete/concrete products	✓✓	roof tiles	✓
sand-lime brick	✓✓	sandstone	✓
brickwork/bricks	✓		

ITEM NUMBER	DESCRIPTION	Ø (MM)	BORE (MM)	NUMBER OF SEGMENTS	SEGMENT THICKNESS (MM)	LIST PRICE RRP (WITHOUT VAT IN EUR)
310019	MSE	115	22,23	8	2,4	
310020	MSE	125	22,23	9	2,4	
310073	MSE	150	22,23	10	2,6	
310028	MSE	180	22,23	14	2,6	
310021	MSE	230	22,23	16	2,8	

TECHNIC

MES



EN 13236 compliant

ADVANTAGES

- Professional diamond blade
- segment height: 10 mm
- universal for construction site
- with packing unit 10 (supplied in cardboard box)

MATERIAL

concrete/concrete products	✓
brickwork/bricks	✓
roof tiles	✓

ITEM NUMBER	DESCRIPTION	Ø (MM)	BORE (MM)	NUMBER OF SEGMENTS	SEGMENT THICKNESS (MM)	LIST PRICE RRP (WITHOUT VAT IN EUR)
310582	MES	115	22,23	9	1,8	
310583	MES	125	22,23	10	1,8	
310584	MES	230	22,23	16	2,4	

SOLID

MSS



EN 13236 compliant

ADVANTAGES

- Standard diamond blade
- segment height: 8 mm
- sintered segments
- block segmented

MATERIAL

concrete/concrete products	✓
brickwork/bricks	✓

ITEM NUMBER	DESCRIPTION	Ø (MM)	BORE (MM)	NUMBER OF SEGMENTS	SEGMENT THICKNESS (MM)	LIST PRICE RRP (WITHOUT VAT IN EUR)
311381	MSS	105	22,23/16	8	1,8	
310977	MSS	115	22,23/16	8	2,0	
310978	MSS	125	22,23	9	2,0	
310979	MSS	180	22,23	13	2,4	
310980	MSS	230	22,23	16	2,4	



CUTTING

UNIVERSAL

SOLID

MTS



EN 13236 compliant

ADVANTAGES

- Standard diamond blade
- segment height: 7 mm
- direct sintering
- Continuous Turbo Rim

MATERIAL

- concrete/concrete products ✓
- brickwork/bricks ✓

ITEM NUMBER	DESCRIPTION	Ø (MM)	BORE (MM)	NUMBER OF SEGMENTS	SEGMENT THICKNESS (MM)	LIST PRICE RRP (WITHOUT VAT IN EUR)
310981	MTS	115	22,23	1	2,4	
310982	MTS	125	22,23	1	3,0	
310983	MTS	180	22,23	1	3,0	
310984	MTS	230	22,23	1	3,2	

MASTER

TPM



EN 13236 compliant



ADVANTAGES

- Premium diamond mortar raker
- segment height: 9 mm
- for joint and slot cutting, 6 and 8 mm cut width
- optimum steel core protection from brazed protection segments
- very high lifetime

MATERIAL

- sand-lime brick ✓✓
- hard cement joints ✓✓
- abrasive cement joints ✓✓
- shell limestone ✓✓

ITEM NUMBER	DESCRIPTION	Ø (MM)	BORE (MM)	NUMBER OF SEGMENTS	SEGMENT THICKNESS (MM)	LIST PRICE RRP (WITHOUT VAT IN EUR)
310227	TPM	115	22,23	8	6,0	
310470	TPM	115	22,23	8	8,0	
310180	TPM	125	22,23	8	6,0	
310453	TPM	125	22,23	8	8,0	

TECHNIC

TPT



EN 13236 compliant



ADVANTAGES

- Professional diamond mortar raker
- segment height: 10 mm
- for joint and slot cutting, 6,4 and 10 mm cut width

MATERIAL

- sand-lime brick ✓
- hard cement joints ✓
- abrasive cement joints ✓
- shell limestone ✓

ITEM NUMBER	DESCRIPTION	Ø (MM)	BORE (MM)	NUMBER OF SEGMENTS	SEGMENT THICKNESS (MM)	LIST PRICE RRP (WITHOUT VAT IN EUR)
310252	TPT	115	22,23	9	6,4	
311387	TPT	115	22,23	10	10,0	
310253	TPT	125	22,23	10	6,4	
311388	TPT	125	22,23	12	10,0	

SHOXX®
POWER INSIDE

GX13       **SILENCIO**

REDUCED NOISE!



**HIGH-END-
DIAMOND BLADE**

WITH **SHOXX**
FORGED SEGMENTS

SEGMENT HEIGHT:
13 MM

**LOW VIBRATION
& CLEAN CUT**

**SILENCIO: MAXIMUM
NOISE REDUCTION**

**SANDWICH
STEEL CORE**



More information

MADE IN GERMANY  LASER WELDED   EN 13236 compliant

MATERIAL

concrete/concrete products	✓✓	reinforced concrete	✓	roof tiles	✓
granite/natural stone	✓✓	washed concrete	✓	quartz	✓
porphyry	✓✓	brickwork/bricks	✓	limestone/travertine	✓

* **SILENCIO = significant noise reduction of approx. 80% compared to the standard steel core.**

ITEM NUMBER	DESCRIPTION	Ø (MM)	BORE (MM)	NUMBER OF SEGMENTS	SEGMENT THICKNESS (MM)	LIST PRICE RRP (WITHOUT VAT IN EUR)
310083	GX13 Silencio	230	22,23	15	2,6	



CUTTING

GRANITE

SHOXX
POWER INSIDE

GX13



EN 13236 compliant

MADE IN GERMANY

LASER WELDED

ADVANTAGES

- High-End-diamond blade with SHOXX forged segments
- segment height: 13 mm
- high lifetime & cut quality
- low vibration and clean cut

MATERIAL

concrete/concrete products	✓✓	washed concrete	✓
granite/natural stone	✓✓	brickwork/bricks	✓
porphyry	✓✓	quartz	✓
roof tiles	✓✓	limestone/travertine	✓
reinforced concrete	✓		

ITEM NUMBER	DESCRIPTION	Ø (MM)	BORE (MM)	NUMBER OF SEGMENTS	SEGMENT THICKNESS (MM)	LIST PRICE RRP (WITHOUT VAT IN EUR)
300106	GX13	230	22,23	16	2,6	

MASTER

GSM SILENCIO

REDUCED NOISE!



EN 13236 compliant

MADE IN GERMANY

LASER WELDED

ADVANTAGES

- Premium diamond blade
- segment height: 11 mm
- max. noise reduction with SILENCIO steel core

MATERIAL

reinforced concrete	✓	granite/natural stone	✓
washed concrete	✓	limestone/travertine	✓
concrete/concrete products	✓	porphyry	✓
brickwork/bricks	✓		

* **SILENCIO** = significant noise reduction of approx. 80% compared to the standard steel core.

ITEM NUMBER	DESCRIPTION	Ø (MM)	BORE (MM)	NUMBER OF SEGMENTS	SEGMENT THICKNESS (MM)	LIST PRICE RRP (WITHOUT VAT IN EUR)
311061	GSM Silencio	125	22,23	8	2,6	
311043	GSM Silencio	230	22,23	15	2,6	

MASTER // GTM



EN 13236 compliant

ADVANTAGES

- Premium diamond blade
- segment height: 10 mm
- Continuous Turbo Rim
- for precision cuts

MATERIAL

roof tiles	✓✓	granite/natural stone	✓
concrete/concrete products	✓	limestone/travertine	✓
brickwork/bricks	✓	porphyry	✓
quartz	✓		

ITEM NUMBER	DESCRIPTION	Ø (MM)	BORE (MM)	NUMBER OF SEGMENTS	SEGMENT THICKNESS (MM)	LIST PRICE RRP (WITHOUT VAT IN EUR)
310237	GTM	115	22,23	1	2,2	
310238	GTM	125	22,23	1	2,2	
310590	GTM	180	22,23	1	2,4	
310239	GTM	230	22,23	1	2,6	

MASTER // TSM



ADVANTAGES

- Premium cut & grind blade
- segment height: 9 mm
- for flush cuts and for bevelling

MATERIAL

granite/natural stone	✓✓	limestone/travertine	✓
concrete/concrete products	✓	porphyry	✓
quartz	✓		

ITEM NUMBER	DESCRIPTION	Ø (MM)	BORE (MM)	NUMBER OF SEGMENTS	SEGMENT THICKNESS (MM)	LIST PRICE RRP (WITHOUT VAT IN EUR)
310591	TSM	125	M14	1	3,0	
310592	TSM	230	M14	1	3,0	

MASTER // GKM



ADVANTAGES

- Premium curved diamond blade
- segment height: 8 mm
- ideal for terrace and patio slabs

MATERIAL

concrete/concrete products	✓
roof tiles	✓
granite/natural stone	✓

ITEM NUMBER	DESCRIPTION	Ø (MM)	BORE (MM)	NUMBER OF SEGMENTS	SEGMENT THICKNESS (MM)	LIST PRICE RRP (WITHOUT VAT IN EUR)
311028	GKM	125	22,23	9	2,6	
311029	GKM	180	22,23	15	2,6	

SHOXX®

POWER INSIDE

KTX 

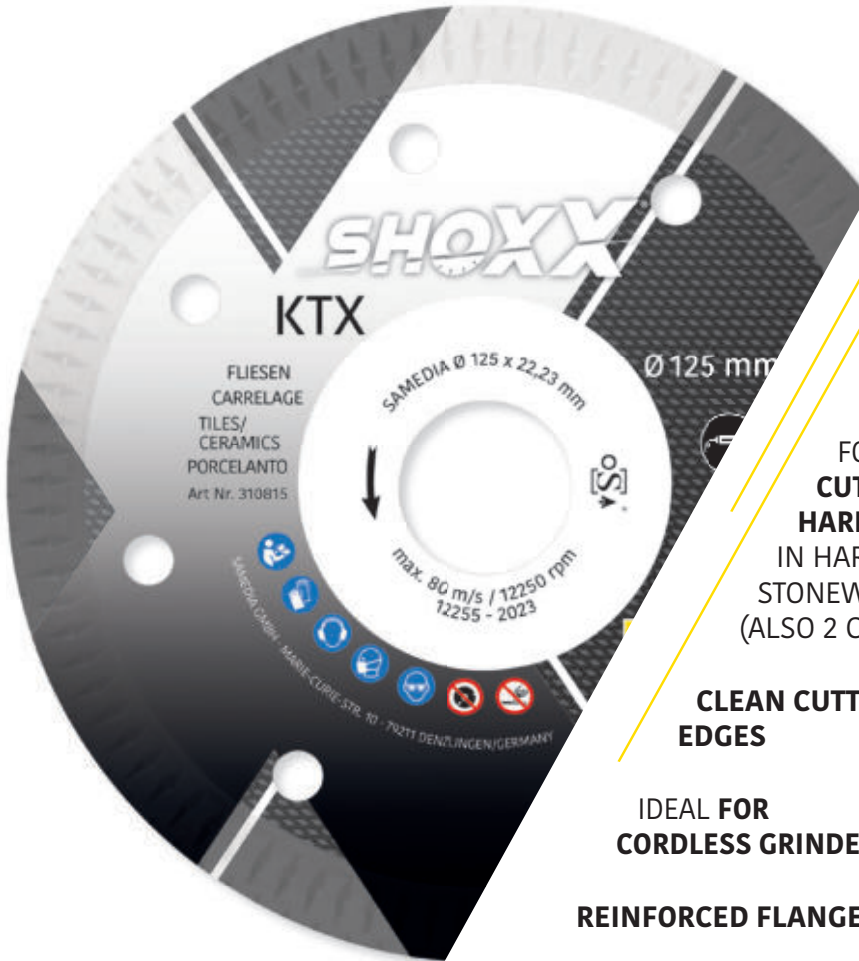

**HIGH-END-
DIAMOND BLADE**

SEGMENT HEIGHT:
10 MM

**FOR QUICK STRAIGHT
CUTS IN THE
HARDEST TILES
IN HARDEST PORCELAIN
STONEWARE
(ALSO 2 CM THICK)**

**CLEAN CUTTING
EDGES**

**IDEAL FOR
CORDLESS GRINDER**

REINFORCED FLANGE



More information



CUTTING

GRANITE

TILES

 **EN 13236**
compliant

MATERIAL

porcelain stoneware	✓✓	artificial stone/marble	✓✓
tiles	✓✓	limestone/travertine	✓
glazed stove tiles	✓✓	stainless steel	✓
granite/natural stone	✓✓		

ITEM NUMBER	DESCRIPTION	Ø (MM)	BORE (MM)	NUMBER OF SEGMENTS	SEGMENT THICKNESS (MM)	LIST PRICE RRP (WITHOUT VAT IN EUR)
310814	KTX	115	22,23	1	1,3	
310815	KTX	125	22,23	1	1,3	

SHOXX®

POWER INSIDE

KVX 



 EN 13236 compliant

ADVANTAGES

- High-End-diamond blade
- segment height: 8 mm
- can be used dry and wet
- extremely clean cutting edges

MATERIAL

porcelain stoneware	✓✓	limestone/travertine	✓
tiles	✓✓	artificial stone/marble	✓
glazed stove tiles	✓✓	stainless steel	✓
granite/natural stone	✓		

ITEM NUMBER	DESCRIPTION	Ø (MM)	BORE (MM)	NUMBER OF SEGMENTS	SEGMENT THICKNESS (MM)	LIST PRICE RRP (WITHOUT VAT IN EUR)
311025	KVX	115	22,23	1	1,5	
311026	KVX	125	22,23	1	1,5	
311078	KVX	150	25,4/22,23	1	1,6	
311081	KVX	230	22,23	1	1,6	

MASTER

KTM 



XLOCK

 EN 13236 compliant

ADVANTAGES

- Premium diamond blade
- segment height: 10 mm
- reinforced flange
- straight cut and smooth running
- quick & clean cut

MATERIAL

porcelain stoneware	✓✓	artificial stone/marble	✓✓
tiles	✓✓	limestone/travertine	✓
glazed stove tiles	✓✓	stainless steel	✓
granite/natural stone	✓✓		

ITEM NUMBER	DESCRIPTION	Ø (MM)	BORE (MM)	NUMBER OF SEGMENTS	SEGMENT THICKNESS (MM)	LIST PRICE RRP (WITHOUT VAT IN EUR)
330016	KTM	115	22,23	1	1,4	
330017	KTM	125	22,23	1	1,4	
311584	KTM XLOCK	125	XLOCK	1	1,4	
330024	KTM	230	22,23	1	1,6	

MASTER

KCM **XLOCK** EN 13236
compliant**ADVANTAGES**

- Premium diamond blade
- segment height: 7 mm
- continuous rim
- clean cut

MATERIAL

porcelain stoneware	✓✓	artificial stone/marble	✓
tiles	✓✓	limestone/travertine	✓
glazed stove tiles	✓✓	stainless steel	✓
granite/natural stone	✓		

ITEM NUMBER	DESCRIPTION	Ø (MM)	BORE (MM)	NUMBER OF SEGMENTS	SEGMENT THICKNESS (MM)	LIST PRICE RRP (WITHOUT VAT IN EUR)
300001	KCM	115	22,23	1	1,5	
300002	KCM	125	22,23	1	1,5	
311585	KCM XLOCK	125	XLOCK	1	1,5	
310015	KCM	150	25,4/22,23	1	1,5	
300005	KCM	230	22,23	1	1,6	

MASTER

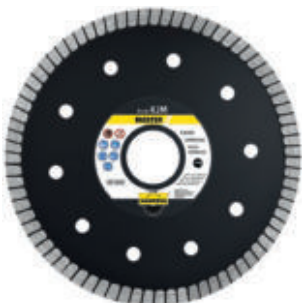
KJM  EN 13236
compliant**ADVANTAGES**

- Premium diamond blade
- segment height: 7 mm
- with reinforced flange (up to Ø 230 mm)
- extra thin Turbo Rim
- quick & clean cut

MATERIAL

porcelain stoneware	✓✓	artificial stone/marble	✓✓
tiles	✓✓	limestone/travertine	✓
glazed stove tiles	✓✓	stainless steel	✓
granite/natural stone	✓✓		

ITEM NUMBER	DESCRIPTION	Ø (MM)	BORE (MM)	NUMBER OF SEGMENTS	SEGMENT THICKNESS (MM)	LIST PRICE RRP (WITHOUT VAT IN EUR)
310626	KJM	115	22,23	1	1,4	
310627	KJM	125	22,23	1	1,4	
311224	KJM	180	22,23	1	1,5	
310630	KJM	230	22,23	1	1,6	



CUTTING

TILES

TECHNIC

KTT





 EN 13236 compliant

ADVANTAGES

- Professional diamond blade
- segment height: 10 mm
- continuous rim
- clean cut

MATERIAL

- tiles 
- porcelain stoneware 

ITEM NUMBER	DESCRIPTION	Ø (MM)	BORE (MM)	NUMBER OF SEGMENTS	SEGMENT THICKNESS (MM)	LIST PRICE RRP (WITHOUT VAT IN EUR)
311661	KTT	115	22,23	1	1,4	
311662	KTT	125	22,23	1	1,4	

TECHNIC

KCT



EN 13236 compliant

ADVANTAGES

- Professional diamond blade
- segment height: 7 mm
- continuous rim
- clean cut
- not suitable for porcelain stoneware and hard tiles

MATERIAL

- tiles 

ITEM NUMBER	DESCRIPTION	Ø (MM)	BORE (MM)	NUMBER OF SEGMENTS	SEGMENT THICKNESS (MM)	LIST PRICE RRP (WITHOUT VAT IN EUR)
330008	KCT	115	22,23	1	1,6	
330009	KCT	125	22,23	1	1,6	
330012	KCT	230	22,23	1	1,6	

SOLID

TCS



EN 13236 compliant

ADVANTAGES

- Standard diamond blade
- segment height: 8 mm
- extra slim for hard tiles
- for clean cuts

MATERIAL

- tiles 

ITEM NUMBER	DESCRIPTION	Ø (MM)	BORE (MM)	NUMBER OF SEGMENTS	SEGMENT THICKNESS (MM)	LIST PRICE RRP (WITHOUT VAT IN EUR)
311237	TCS	115	22,23	1	1,2	

SOLID

KCS 



EN 13236 compliant

ADVANTAGES

- Standard diamond blade
- segment height: 6 mm
- direct sintering
- continuous rim

MATERIAL

tiles 

ITEM NUMBER	DESCRIPTION	Ø (MM)	BORE (MM)	NUMBER OF SEGMENTS	SEGMENT THICKNESS (MM)	LIST PRICE RRP (WITHOUT VAT IN EUR)
310985	KCS	115	22,23	1	2,0	
310986	KCS	125	22,23	1	2,0	
310987	KCS	180	22,23	1	2,8	
310988	KCS	230	22,23	1	3,0	

MASTER // **TILER-SETS** 



SET COMPONENTS

POS. 1 (380813)

- 4x DBV (Ø20/38/45/65 mm)
- 1x diamond blade KTM (Ø125x22,23)
- 1x diamond grinding cup wheel Z-A5 (Ø125x22,23)

POS. 2 (380814)

- 5x DBV (Ø20/32/38/45/68 mm)
- 3x diamond hand grinding pads HSP (granulation 120/200/400)
- 1x diamond blade KTM (Ø125x22,23)
- 1x Diamond grinding cup wheel UBM (Ø125x22,23)

POS.	ITEM NUMBER	DESCRIPTION	LIST PRICE RRP (WITHOUT VAT IN EUR)
1	380813	Profi-Set tiler 1, 6-pcs.	
2	380814	Profi-Set tiler 2, 10-pcs.	



Save cost!



CUTTING

TILES

SHOXX®
POWER INSIDE

KX13  **SILENCIO**

REDUCED NOISE!



**HIGH-END-DIAMOND
BLADE**

WITH **SHOXX**
FORGED SEGMENTS

SEGMENT HEIGHT:
13 MM

**MAXIMUM NOISE
REDUCTION THANKS
TO SILENCIO SAND-
WICH CORE**

FOR **HARD BRICKS,
CLINKER**



More information

MADE IN GERMANY  LASER WELDED   EN 13236 compliant

MATERIAL

hard bricks	✓✓	concrete/concrete products	✓
reinforced concrete	✓	slate	✓

ITEM NUMBER	DESCRIPTION	Ø (MM)	BORE (MM)	NUMBER OF SEGMENTS	SEGMENT THICKNESS (MM)	LIST PRICE RRP (WITHOUT VAT IN EUR)
310143	KX13 Silencio	230	22,23	15	2,6	

* **SILENCIO** = significant noise reduction of approx. 80% compared to the standard steel core



SHOXX
POWER INSIDE

KX13 ◆◆◆◆◆◆◆◆



EN 13236 compliant

MADE IN GERMANY

LASER WELDED

ADVANTAGES

- HighEnd-diamond blade
- with SHOXX forged segments
- segment height: 13 mm
- for hard bricks, clinker

MATERIAL

hard bricks	✓✓	concrete/concrete products	✓
reinforced concrete	✓	slate	✓

ITEM NUMBER	DESCRIPTION	Ø (MM)	BORE (MM)	NUMBER OF SEGMENTS	SEGMENT THICKNESS (MM)	LIST PRICE RRP (WITHOUT VAT IN EUR)
310142	KX13	230	22,23	15	2,6	

SHOXX
POWER INSIDE

TX13 ◆◆◆◆◆◆◆◆



EN 13236 compliant

MADE IN GERMANY

LASER WELDED

ADVANTAGES

- HighEnd-diamond blade
- with SHOXX forged segments
- segment height: 13 mm
- low vibration & clean cut
- the universal blade for construction
- 3 segment types - application categories (concrete/asphalt)

MATERIAL

reinforced concrete	✓✓
concrete/concrete products	✓✓
screed	✓✓
asphalt	✓✓

ITEM NUMBER	DESCRIPTION	Ø (MM)	BORE (MM)	NUMBER OF SEGMENTS	SEGMENT THICKNESS (MM)	LIST PRICE RRP (WITHOUT VAT IN EUR)
310910	TX13	230	22,23	15	2,6	

MASTER

VFM ◆◆◆◆◆◆◆◆



EN 13236 compliant

ADVANTAGES

- Premium V-groove milling cutter
- segment height 12 mm sharp
- for repairing cracks
- segment width 9,5 mm
- only for wet cutting

MATERIAL

reinforced concrete	✓✓	sandstone	✓✓
concrete/concrete products	✓✓	screed	✓✓
sand-lime brick	✓✓	asphalt	✓✓

ITEM NUMBER	DESCRIPTION	Ø (MM)	BORE (MM)	NUMBER OF SEGMENTS	SEGMENT THICKNESS (MM)	LIST PRICE RRP (WITHOUT VAT IN EUR)
310413	VFM	125	22,23	9	12,0	
310414	VFM	230	25,40	16	12,0	

MASTER PVM



 EN 13236 compliant

ADVANTAGES

- Premium diamond tool
- segment height: 3 mm
- combined tool for cutting and bevelling pipes
- vacuum brazed diamond coating
- 20° chamfer

MATERIAL

ductile iron pipes	✓✓
PVC-/KG-/HT-pipes	✓✓
plastic/GfK	✓✓

ITEM NUMBER	DESCRIPTION	Ø (MM)	BORE (MM)	NUMBER OF SEGMENTS	SEGMENT THICKNESS (MM)	LIST PRICE RRP (WITHOUT VAT IN EUR)
310685	PVM	125	22,23	9	3,0	

MASTER RFS-SET

3 PIECES



ADVANTAGES

- Premium diamond tool for cutting and chamfering (Ø125 and 230 mm)
- for cutting and chamfering of thermal sensitive sewer pipes made of PP/PE and PVC
- with ball-bearing wheel for optimum guidance

SET COMPONENTS

- RFS-cutting disc
- RFS-chamfer cutter with carbide cutting blades
- RFS-guide roller ball bearing M14

MATERIAL

PP-/PE-/PVC-pipes	✓✓
plastic/GfK	✓✓

ITEM NUMBER	DESCRIPTION	LIST PRICE RRP (WITHOUT VAT IN EUR)
390724	RFS-Set Ø125 mm M14 3-pieces	
311514	RFS-Set replacement Ø125: cutting disc (for 390724)	
311515	RFS-Set replacement Ø125: chamfer cutter (for 390724)	
311516	RFS-Set replacement Ø125: guide roller ball (for 390724)	
311723	RFS-Set Ø230 mm M14 3-pieces	
311724	RFS-Set replacement Ø230: cutting disc (für 311723)	
311725	RFS-Set replacement Ø230: chamfer cutter (für 311723)	
311726	RFS-Set replacement Ø230: guide roller ball (für 311723)	

MASTER UVM



 EN 13236 compliant

ADVANTAGES

- vacuum brazed All-Cut diamond blade
- segment height: 3 mm
- universal use/rescue blade

MATERIAL

ductile iron pipes	✓✓	concrete/concrete products	✓
PVC-/KG-/HT-pipes	✓✓	brickwork/bricks	✓
plastic/GfK	✓✓	roof tiles	✓
metal/steel	✓	timber/laminate	✓

ITEM NUMBER	DESCRIPTION	Ø (MM)	BORE (MM)	NUMBER OF SEGMENTS	SEGMENT THICKNESS (MM)	LIST PRICE RRP (WITHOUT VAT IN EUR)
310795	UVM	115	22,23	9	3,0	
310796	UVM	125	22,23	10	3,0	
310797	UVM	230	22,23	16	3,0	

MASTER UTM



EN 13236
compliant

ADVANTAGES

- vacuum-brazed Premium diamond cutting disc for metal application
- extra-thin execution for a fast and clean cut
- more power, up to 1000 cuts = 30 x more lifetime in comparison to corandum discs
- more comfortable because of constant cutting depth
- no reduction of diameter possible
- more safety because of less flying sparks

MATERIAL

metal/steel	✓✓
ductile iron pipes	✓✓
stainless steel	✓
PVC-/KG-/HT-pipes	✓
plastic/GfK	✓

ITEM NUMBER	DESCRIPTION	Ø (MM)	BORE (MM)	NUMBER OF SEGMENTS	SEGMENT THICKNESS (MM)	LIST PRICE RRP (WITHOUT VAT IN EUR)
311793	UTM	115	22,23	1	1,5	
311794	UTM	125	22,23	1	1,5	
311796	UTM	230	22,23	1	1,5	

MASTER HLK



ADVANTAGES

- carbide grit coated Premium All-Cut blade
- segment height: 1 mm
- for a clean and quick cut
- extra-thin, little dust, durable
- ideal for ideal for cordless grinders

MATERIAL

PVC-/KG-/HT-pipes	✓✓
PP-/PE-/PVC-pipes	✓✓
plastic/GfK	✓✓
timber/laminate	✓✓

ITEM NUMBER	DESCRIPTION	Ø (MM)	BORE (MM)	NUMBER OF SEGMENTS	SEGMENT THICKNESS (MM)	LIST PRICE RRP (WITHOUT VAT IN EUR)
320027	HLK	115	22,23	8	1,0	
320023	HLK	125	22,23	9	1,0	
320028	HLK	230	22,23	16	2,5	

MASTER UGM



ADVANTAGES

- Premium electro-plated diamond blade
- segment height: 3 mm
- with M14 flange for flush cutting
- very high cut quality, clean cutting edge
- diamond-coated on both sides

MATERIAL

tiles	✓✓	concrete/concrete products	✓
artificial stone/marble	✓✓	granite/natural stone	✓
plastic/GfK	✓✓	metal/steel	✓
glass/fibre-glass	✓✓		

ITEM NUMBER	DESCRIPTION	Ø (MM)	BORE (MM)	NUMBER OF SEGMENTS	SEGMENT THICKNESS (MM)	LIST PRICE RRP (WITHOUT VAT IN EUR)
311090	UGM	125	M14	1	2,0	
311091	UGM	230	M14	1	2,0	



CUTTING

SPECIAL

MASTER // TKE



 EN 13236 compliant

ADVANTAGES

- Premium Corandum blade INOX
- cuts clean & slim, without burrs and overheating
- sulphur-free, no rust formation on stainless steel

MATERIAL

metal/steel	✓✓
stainless steel	✓✓

ITEM NUMBER	DESCRIPTION	Ø (MM)	BORE (MM)	VPE (PIECE)	LIST PRICE RRP (WITHOUT VAT IN EUR)
380869	TKE	115 x 1,0	22,23	1 (10 piece tin)	
380870	TKE	125 x 1,0	22,23	1 (10 piece tin)	
320008	TKE	115 x 1,0	22,23	25	
320009	TKE	125 x 1,0	22,23	25	
320010	TKE	230 x 1,9	22,23	25	

*with packing unit 25 (supplied in a cardboard box)

MASTER // TKM



 EN 13236 compliant

ADVANTAGES

- Premium Corandum blade METAL
- stable cut in thick materials

MATERIAL

metal/steel	✓✓
-------------	----

ITEM NUMBER	DESCRIPTION	Ø (MM)	BORE (MM)	VPE (PIECE)	LIST PRICE RRP (WITHOUT VAT IN EUR)
320003	TKM	115 x 2,5	22,23	25	
320004	TKM	125 x 2,5	22,23	25	
320005	TKM	230 x 3,0	22,23	25	

*with packing unit 25 (supplied in a cardboard box)

MASTER SMT



EN 13236
compliant

ADVANTAGES

- Premium abrasive flap disc
- highly versatile abrasive flap disc for metal processing
- long service life with steep edges in corners

MATERIAL

metal/steel



ITEM NUMBER	DESCRIPTION	Ø (MM)	KORN	BORE (MM)	VPE (PIECE)	LIST PRICE RRP (WITHOUT VAT IN EUR)
320011	SMT	115	40	22,23	10	
320012	SMT	115	60	22,23	10	
320013	SMT	115	80	22,23	10	
320014	SMT	125	40	22,23	10	
320015	SMT	125	60	22,23	10	
320016	SMT	125	80	22,23	10	

* with packing unit 10 (supplied in a cardboard box)

TECHNIC GAV



ADVANTAGES

- Professional electro-plated diamond blade
- segment height: 3 mm
- for universal use
- very high cut quality, clean cutting edge
- ideal for dry-cutting of marble

MATERIAL

artificial stone/marble



plastic/GfK



glass/fibre-glass



ITEM NUMBER	DESCRIPTION	Ø (MM)	BORE (MM)	NUMBER OF SEGMENTS	SEGMENT THICKNESS (MM)	LIST PRICE RRP (WITHOUT VAT IN EUR)
311020	GAV	115	22,23	14	2,3	
311021	GAV	125	22,23	12	2,3	
311022	GAV	180	22,23	18	2,6	
311023	GAV	230	22,23	22	2,8	



CUTTING

SPECIAL

RECOMMENDATION TABLE CUT-OFF PETROL SAWS

MATERIAL	CONCRETE						UNIV.		ASPHALT			SPECIAL						
	RX13	UX17	XR20	BX13	BGM	BSE	MX13	MST	AX13	ASM	AST	KX13	TX13	RFM	FSM	FS4	UVM	
	SHOXX			MASTER			SHOXX	MASTER	SHOXX	MASTER	TECHNIC	SHOXX		MASTER				
segment height	13	17	20	13	13	10	13	11	13	11	11	13	13	10	11	9	3	
diameter (mm)	300-400	300-400	350	300-400	300-400	300-400	300-400	300-400	300-400	300-400	300-400	300-400	300-400	350	300-400	300-400	300-400	
page	38	39	40	40	40	41	41	41	42	43	43	44	45	45	46	46	46	
reinforced concrete	✓✓	✓✓	✓✓	✓✓	✓✓	✓	✓✓	✓					✓					
washed concrete	✓✓	✓✓	✓✓	✓✓	✓	✓	✓	✓										
concrete/concrete products	✓✓	✓✓	✓✓	✓✓	✓✓	✓✓	✓✓	✓✓	✓	✓	✓	✓	✓✓	✓✓			✓	
brickwork/bricks	✓✓	✓✓	✓✓	✓✓	✓✓	✓✓	✓✓	✓✓										
sand-lime brick	✓	✓✓	✓✓	✓	✓	✓	✓✓	✓										
sandstone	✓	✓✓	✓✓	✓	✓	✓	✓✓	✓										
granite/natural stone	✓	✓	✓	✓✓	✓	✓												
porphyry	✓	✓	✓	✓	✓	✓												
screed		✓	✓				✓		✓✓	✓	✓		✓	✓✓				
asphalt		✓	✓				✓		✓✓	✓✓	✓✓		✓	✓✓				
green concrete															✓✓	✓✓		
hard bricks												✓✓						
metal/steel	✓	✓	✓														✓	
plastic/GfK																	✓	



RX13



OS EN 13236
compliant

MADE IN
GERMANY

LASER
WELDED

ADVANTAGES

- High-End-diamond blade with SHOXX forged segments
- segment height: 13 mm
- maximum cutting speed
- clean cut

MATERIAL

reinforced concrete	✓✓	sandstone	✓
washed concrete	✓✓	granite/natural stone	✓
concrete/concrete products	✓✓	porphyry	✓
brickwork/bricks	✓✓	metal/steel	✓
sand-lime brick	✓		

ITEM NUMBER	DESCRIPTION	Ø (MM)	BORE (MM)	NUMBER OF SEGMENTS	SEGMENT THICKNESS (MM)	LIST PRICE RRP (WITHOUT VAT IN EUR)
310621	RX13	300	20,00	20	2,8	
310608	RX13	300	22,23	18	2,8	
310622	RX13	300	25,40	20	2,8	
310528	RX13	350	20,00	21	3,0	
310529	RX13	350	25,40	21	3,0	
310623	RX13	400	20,00	24	3,2	
310624	RX13	400	25,40	24	3,2	

SHOXX®
POWER INSIDE

UX17 



**HIGH-END-
DIAMOND BLADE**

WITH **SHOXX**
FORGED SEGMENTS

SEGMENT HEIGHT:
17 MM

**THE HIGHEST
LIFE TIME & CUTTING
PROPERTIES**

LOW VIBRATION &
CLEAN CUT

**MAXIMUM
VERSATILITY**



More information



CUTTING

CONCRETE

MADE IN GERMANY  LASER WELDED   EN 13236 compliant

MATERIAL

reinforced concrete	✓✓	brickwork/bricks	✓✓	granite/natural stone	✓	asphalt	✓
washed concrete	✓✓	sand-lime brick	✓✓	porphyry	✓	metal/steel	✓
concrete/concrete products	✓✓	sandstone	✓✓	screed	✓		

ITEM NUMBER	DESCRIPTION	Ø (MM)	BORE (MM)	NUMBER OF SEGMENTS	SEGMENT THICKNESS (MM)	LIST PRICE RRP (WITHOUT VAT IN EUR)
310138	UX17	300	20	19	2,8	
310139	UX17	300	25,4	19	2,8	
310140	UX17	350	20	22	3,0	
310141	UX17	350	25,4	22	3,0	
310200	UX17	400	20	25	3,2	
310201	UX17	400	25,4	25	3,2	

SHOXX
POWER INSIDE

XR20 ♦♦♦♦♦♦



EN 13236 compliant

MADE IN GERMANY

LASER WELDED

ADVANTAGES

- unique and exclusive diamond blade with SHOXX forged segments
- segment height: 20 mm
- high life time and clean cut
- low vibration and clean cut

MATERIAL

reinforced concrete	✓✓	granite/natural stone	✓
washed concrete	✓✓	porphyry	✓
concrete/concrete products	✓✓	screed	✓
brickwork/bricks	✓✓	asphalt	✓
sand-lime brick	✓✓	metal/steel	✓
sandstone	✓✓		

ITEM NUMBER	DESCRIPTION	Ø (MM)	BORE (MM)	NUMBER OF SEGMENTS	SEGMENT THICKNESS (MM)	LIST PRICE RRP (WITHOUT VAT IN EUR)
311628	XR20	350	20,00	42	3,2	
311629	XR20	350	25,40	42	3,2	

SHOXX
POWER INSIDE

BX13 ♦♦♦♦♦♦



EN 13236 compliant

MADE IN GERMANY

LASER WELDED

ADVANTAGES

- High-End-diamond blade with SHOXX forged segments
- segment height: 13 mm
- the highest life time & cutting properties
- low vibration and clean cut

MATERIAL

reinforced concrete	✓✓	sand-lime brick	✓
washed concrete	✓✓	sandstone	✓
concrete/concrete products	✓✓	porphyry	✓
granite/natural stone	✓✓		
brickwork/bricks	✓✓		

ITEM NUMBER	DESCRIPTION	Ø (MM)	BORE (MM)	NUMBER OF SEGMENTS	SEGMENT THICKNESS (MM)	LIST PRICE RRP (WITHOUT VAT IN EUR)
310763	BX13	300	20,00	20	2,8	
312052	BX13	300	22,23	20	2,8	
310065	BX13	300	25,4/20	20	2,8	
310048	BX13	350	20,00	21	3,0	
310049	BX13	350	25,4/20	21	3,0	
310050	BX13	350	30/25,4	21	3,0	
310067	BX13	400	20,00	24	3,2	
310057	BX13	400	25,4/20	24	3,2	

MASTER

BGM ♦♦♦♦♦♦



EN 13236 compliant

MADE IN GERMANY

LASER WELDED

ADVANTAGES

- Premium-diamond blade
- segment height: 13 mm
- high life time & cut quality
- low vibration

MATERIAL

reinforced concrete	✓✓	sand-lime brick	✓
concrete/concrete products	✓✓	sandstone	✓
brickwork/bricks	✓✓	granite/natural stone	✓
washed concrete	✓	porphyry	✓

ITEM NUMBER	DESCRIPTION	Ø (MM)	BORE (MM)	NUMBER OF SEGMENTS	SEGMENT THICKNESS (MM)	LIST PRICE RRP (WITHOUT VAT IN EUR)
310831	BGM	300	20,00	18	2,8	
310832	BGM	300	25,40	18	2,8	
310540	BGM	350	20,00	21	3,0	
310541	BGM	350	25,40	21	3,0	
310833	BGM	400	20,00	24	3,2	
310834	BGM	400	25,40	24	3,2	



CUTTING

CONCRETE

UNIVERSAL

MASTER BSE

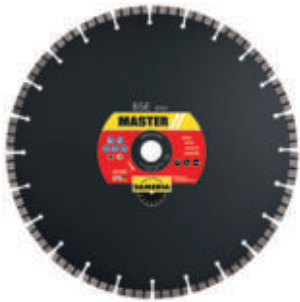

EN 13236 compliant

MADE IN GERMANY AB Ø230

LASER WELDED

ADVANTAGES

- Premium-diamond blade
- segment height: 10 mm

MATERIAL

concrete/concrete products	✓✓	sand-lime brick	✓
brickwork/bricks	✓✓	sandstone	✓
reinforced concrete	✓	granite/natural stone	✓
washed concrete	✓	porphyry	✓

ITEM NUMBER	DESCRIPTION	Ø (MM)	BORE (MM)	NUMBER OF SEGMENTS	SEGMENT THICKNESS (MM)	LIST PRICE RRP (WITHOUT VAT IN EUR)
310026	BSE	300	20,00	20	2,8	
311368	BSE	300	22,23	20	2,8	
311057	BSE	300	25,40	20	2,8	
310090	BSE	350	20,00	24	3,0	
310027	BSE	350	25,40	24	3,0	
311058	BSE	400	20,00	26	3,2	
310120	BSE	400	25,40	26	3,2	

SHOXX MX13



EN 13236 compliant

MADE IN GERMANY

LASER WELDED

ADVANTAGES

- HighEnd-diamond blade with SHOXX forged segments
- segment height: 13 mm
- high life time and clean cut
- particularly suitable for abrasive materials

MATERIAL

reinforced concrete	✓✓	sandstone	✓✓
concrete/concrete products	✓✓	washed concrete	✓
brickwork/bricks	✓✓	screed	✓
sand-lime brick	✓✓	asphalt	✓

ITEM NUMBER	DESCRIPTION	Ø (MM)	BORE (MM)	NUMBER OF SEGMENTS	SEGMENT THICKNESS (MM)	LIST PRICE RRP (WITHOUT VAT IN EUR)
310350	MX13	300	20	20	2,8	
310351	MX13	300	25,4	20	2,8	
310352	MX13	350	20	24	3,0	
310353	MX13	350	25,4	24	3,0	
310354	MX13	400	20	28	3,2	
310355	MX13	400	25,4	28	3,2	

MASTER MST



EN 13236 compliant

MADE IN GERMANY

LASER WELDED

ADVANTAGES

- Premium-diamond blade
- segment height: 11 mm
- universal range of applications

MATERIAL

concrete/concrete products	✓✓	washed concrete	✓
brickwork/bricks	✓✓	sand-lime brick	✓
reinforced concrete	✓	sandstone	✓

ITEM NUMBER	DESCRIPTION	Ø (MM)	BORE (MM)	NUMBER OF SEGMENTS	SEGMENT THICKNESS (MM)	LIST PRICE RRP (WITHOUT VAT IN EUR)
310369	MST	300	20,00	18	2,8	
310370	MST	300	25,40	18	2,8	
310371	MST	350	20,00	21	3,0	
310372	MST	350	25,40	21	3,0	
310373	MST	400	20,00	24	3,2	
310374	MST	400	25,40	24	3,2	

SHOXX

POWER INSIDE

AX13



**HIGH-END-
DIAMOND BLADE**

WITH **SHOXX**
FORGED SEGMENTS

SEGMENT HEIGHT:
13 MM

**HIGH LIFETIME
& CUTTING PROPERTIES**

**DEEP PROTECTION
SEGMENTS**

LOW VIBRATION

IDEAL UP TO 25 KW



More information



MATERIAL

- asphalt ✓✓
- screed ✓✓
- concrete/concrete products ✓

ITEM NUMBER	DESCRIPTION	Ø (MM)	BORE (MM)	NUMBER OF SEGMENTS	SEGMENT THICKNESS (MM)	LIST PRICE RRP (WITHOUT VAT IN EUR)
310336	AX13	300	20	18	2,8	
310337	AX13	300	25,4	18	2,8	
310338	AX13	350	20	21	3,0	
310339	AX13	350	25,4	21	3,0	
310340	AX13	400	20	24	3,2	
310341	AX13	400	25,4	24	3,2	

MASTER // ASM



 EN 13236 compliant

MADE IN GERMANY 

LASER WELDED 

ADVANTAGES

- Premium diamond blade
- segment height: 11 mm
- DEEP protection segments
- ideal for cut-off petrol saw, floor saws up to 25 kW

MATERIAL

asphalt	✓✓
screed	✓
concrete/concrete products	✓

ITEM NUMBER	DESCRIPTION	Ø (MM)	BORE (MM)	NUMBER OF SEGMENTS	SEGMENT THICKNESS (MM)	LIST PRICE RRP (WITHOUT VAT IN EUR)
310131	ASM	300	20	18	2,8	
300044	ASM	300	25,4	18	2,8	
310132	ASM	350	20	21	3,0	
300045	ASM	350	25,4	21	3,0	
310134	ASM	400	20	24	3,2	
300046	ASM	400	25,4	24	3,2	

TECHNIC // AST



 EN 13236 compliant

MADE IN GERMANY 

LASER WELDED 

ADVANTAGES

- Professional diamond blade
- segment height: 11 mm
- DEEP protection segments
- ideal for cut-off petrol saw and floor saws up to 7.5 kW

MATERIAL

asphalt	✓✓
screed	✓
concrete/concrete products	✓

ITEM NUMBER	DESCRIPTION	Ø (MM)	BORE (MM)	NUMBER OF SEGMENTS	SEGMENT THICKNESS (MM)	LIST PRICE RRP (WITHOUT VAT IN EUR)
310075	AST	300	20,00	18	2,8	
310076	AST	350	25,4/20	21	3,0	
310072	AST	400	25,40	24	3,2	



CUTTING

ASPHALT

SHOXX®

POWER INSIDE

KX13

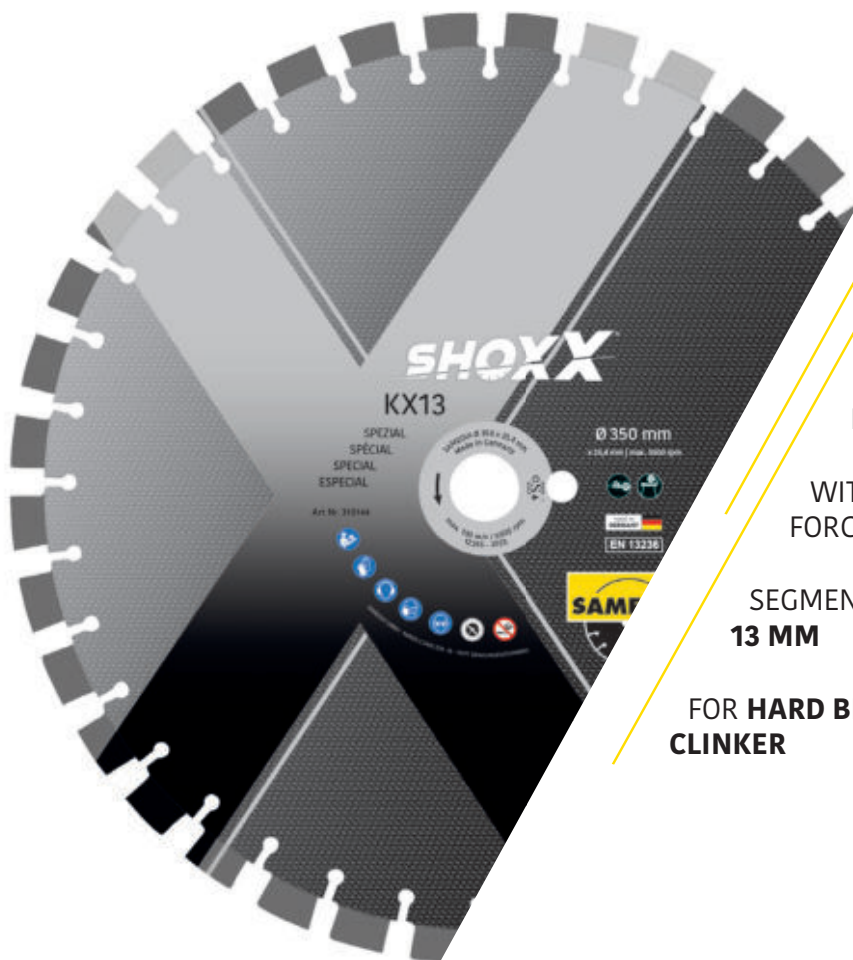

**HIGH-END-
DIAMOND BLADE**

WITH **SHOXX**
FORGED SEGMENTS

SEGMENT HEIGHT:
13 MM

FOR **HARD BRICKS,
CLINKER**



More information



ITEM NUMBER	DESCRIPTION	Ø (MM)	BORE (MM)	NUMBER OF SEGMENTS	SEGMENT THICKNESS (MM)	LIST PRICE RRP (WITHOUT VAT IN EUR)
310088	KX13	300	25,40	18	2,8	
310089	KX13	350	30/25,4	21	3,0	
310144*	KX13	350	25,40	36	3,0	
310535	KX13	400	25,40	24	3,0	

* SHOXX KX13/K 350x25,4 with short segments

MATERIAL

hard bricks ✓✓

concrete/concrete products ✓



CUTTING

SPECIAL



TX13



EN 13236 compliant

MADE IN GERMANY

LASER WELDED

ADVANTAGES

- High-End-diamond blade with SHOXX forged segments
- segment height: 13 mm
- low vibration and clean cut
- the universal blade for construction
- 3 segment types - application categories (concrete/asphalt)

MATERIAL

concrete/concrete products	✓✓
reinforced concrete	✓
screed	✓
asphalt	✓

ITEM NUMBER	DESCRIPTION	Ø (MM)	BORE (MM)	NUMBER OF SEGMENTS	SEGMENT THICKNESS (MM)	LIST PRICE RRP (WITHOUT VAT IN EUR)
310911	TX13	300	20,00	18	2,8	
310912	TX13	300	25,4/20	18	2,8	
310913	TX13	350	20,00	21	3,0	
310905	TX13	350	25,4/20	21	3,0	
310914	TX13	400	20,00	24	3,2	
310915	TX13	400	25,4/20	24	3,2	

MASTER RFM



EN 13236 compliant

MADE IN GERMANY

LASER WELDED

ADVANTAGES

- Premium milling wheel for crack/joint widening
- segment height: 10 mm
- special alloy for asphalt and concrete

MATERIAL

concrete/concrete products	✓✓
screed	✓✓
asphalt	✓✓

ITEM NUMBER	DESCRIPTION	Ø (MM)	BORE (MM)	NUMBER OF SEGMENTS	SEGMENT THICKNESS (MM)	LIST PRICE RRP (WITHOUT VAT IN EUR)
310633	RFM	350	25,40	21	8,0	
310521	RFM	350	25,40	21	10,0	

MASTER // FSM



EN 13236 compliant

MADE IN GERMANY

LASER WELDED

ADVANTAGES

- Premium green concrete blade up to 24 h.
- segment height: 11 mm
- with brazed TIP-Segments for steel core protection
- for floor saws up to 25 kW

MATERIAL

green concrete

ITEM NUMBER	DESCRIPTION	Ø (MM)	BORE (MM)	NUMBER OF SEGMENTS	SEGMENT THICKNESS (MM)	LIST PRICE RRP (WITHOUT VAT IN EUR)
311486	FSM	300	25,40	20	2,8	
310030	FSM	350	25,40	24	3,2	
310273	FSM	400	25,40	28	3,2	

MASTER // FSA



EN 13236 compliant

MADE IN GERMANY

LASER WELDED

ADVANTAGES

- Premium green concrete blade 24-48 h
- segment height: 9 mm
- with brazed TIP-Segments for steel core protection
- for floor saws up to 25 kW

MATERIAL

green concrete

ITEM NUMBER	DESCRIPTION	Ø (MM)	BORE (MM)	NUMBER OF SEGMENTS	SEGMENT THICKNESS (MM)	LIST PRICE RRP (WITHOUT VAT IN EUR)
310930	FSA	300	25,40	20	2,8	
310403	FSA	350	25,40	24	2,8	
310301	FSA	400	25,40	28	3,2	

MASTER // UVM



EN 13236 compliant

ADVANTAGES

- vacuum brazed All-Cut diamond blade
- segment height: 3 mm
- universal use/rescue blade

MATERIAL

concrete/concrete products

metal/steel

plastic/GfK

ITEM NUMBER	DESCRIPTION	Ø (MM)	BORE (MM)	NUMBER OF SEGMENTS	SEGMENT THICKNESS (MM)	LIST PRICE RRP (WITHOUT VAT IN EUR)
310798	UVM	300	25,4/20	21	3,0	
310799	UVM	350	25,4/20	24	3,0	
310800	UVM	400	25,4/20	28	3,0	

RECOMMENDATION TABLE
TABLE SAWS
& TILECUTTERS

MATERIAL	CONCRETE								UNIV.	GRANITE				PORCELAIN STONEWARE/TILES					SPECIAL	
	UX13 AMPHIBIA	BX13	BX13 SILENCIO	BGM	USM	UB13	MX13	MST		GX20 SILENCIO	GX13 SILENCIO	GX13	GSM SILENCIO	GTM	KSX	KVX	KCM	KJM	KCT	KX13 SILENCIO
	SHOXX		MASTER		SHOXX	SHOXX	MASTER		SHOXX		MASTER		SHOXX	MASTER	SHOXX	MASTER	TECHNIC	SHOXX		
segment height	13	13	13	13	11	13	13	11	20	13	13	11	10	8	8	7	7	7	13	13
diameter (mm)	300-600	300-450	350-450	300-450	300-1000	700-900	300-400	300-400	400-600	300-450	300-450	250-900	230-350	180-350	150-350	150-350	150-350	115-230	300-350	300-400
FOR TABLESAWS	•	•	•	•	•	•	•	•	•	•	•	•	•	•	•	•	•	•	•	•
FOR TILECUTTERS														•	•	•	•	•		
page	48	49	49	49	50	50	51	51	52	52	52	53	53	54	55	55	56	56	57	57
reinforced concrete	✓✓	✓✓	✓✓	✓	✓	✓✓	✓✓	✓		✓	✓	✓	✓						✓	✓
washed concrete	✓✓	✓✓	✓✓	✓	✓		✓	✓		✓	✓	✓	✓						✓	✓
concrete/concrete products	✓✓	✓✓	✓✓	✓✓	✓	✓✓	✓✓	✓✓		✓✓	✓✓	✓	✓						✓✓	✓✓
extreme dense sand-lime brick	✓				✓	✓✓													✓	✓
brickwork/bricks	✓✓	✓✓	✓✓	✓✓	✓✓	✓✓	✓✓	✓✓		✓✓	✓✓	✓✓	✓✓						✓✓	✓✓
sand-lime brick	✓✓	✓	✓	✓	✓	✓✓	✓✓	✓											✓✓	✓✓
sandstone	✓✓	✓	✓	✓	✓		✓✓	✓											✓✓	✓✓
fire brick/refractory brick	✓																			
quartz									✓	✓	✓	✓	✓✓	✓						
granite/natural stone	✓	✓	✓	✓	✓	✓✓			✓✓	✓✓	✓✓	✓✓	✓✓	✓✓	✓	✓	✓			
limestone/travertine	✓								✓	✓	✓	✓	✓	✓						
porphyry	✓								✓	✓✓	✓✓	✓	✓	✓						
tiles													✓	✓	✓✓	✓✓	✓✓	✓✓		
porcelain stoneware													✓	✓✓	✓✓	✓✓	✓			
porcelain stoneware 2-3cm														✓✓		✓	✓			
ceramic composite panel	✓													✓✓		✓	✓✓			
artificial stone/marble														✓✓		✓	✓			
hard bricks														✓		✓			✓✓	✓✓

* SILENCIO = significant noise reduction of approx. 80% compared to the standard steel core.



CUTTING

SPECIAL

SHOXX
POWER INSIDE

UX13 AMPHIBIA

REDUCED NOISE!



HIGH-END-DIAMOND BLADE

WITH **SHOXX** FORGED SEGMENTS

SEGMENT HEIGHT: **13 MM**

QUIET NOISE REDUCED TO PROTECT USERS AND THE ENVIRONMENT

EFFICIENT **SHARP AND CLEAN** FULL CUTS

VERSATILE UNIVERSAL FOR DRY AND WET CUTTING



More information

MADE IN GERMANY LASER WELDED EN 13236 compliant

MATERIAL

reinforced concrete	✓✓	brickwork/bricks	✓✓	extreme dense sand-lime brick	✓	limestone/travertine	✓
washed concrete	✓✓	sand-lime brick	✓✓	fire brick/refractory brick	✓	porphyry	✓
concrete/concrete products	✓✓	sandstone	✓✓	granite/natural stone	✓	ceramic composite panel	✓

* **SILENCIO** = significant noise reduction of approx. 80% compared to the standard steel core.

ITEM NUMBER	DESCRIPTION	Ø (MM)	BORE (MM)	NUMBER OF SEGMENTS	SEGMENT THICKNESS (MM)	LIST PRICE RRP (WITHOUT VAT IN EUR)
311712	UX13 Amphibia	300	30/25,4	36	2,8	
311713	UX13 Amphibia	350	30/25,4	36	3,0	
311714	UX13 Amphibia	400	30/25,4	48	3,6	
311715	UX13 Amphibia	450	30/25,4	48	3,6	
311741	UX13 Amphibia	500	30/25,4	30	3,6	
311716	UX13 Amphibia	600	60/25,4	36	3,6	



CUTTING

CONCRETE

SHOXX
POWER INSIDE

BX13 ♦♦♦♦♦



OS EN 13236 compliant

MADE IN GERMANY

LASER WELDED

ADVANTAGES

- High-End-diamond blade with SHOXX forged segments
- segment height: 13 mm
- the highest life time & cutting properties
- low vibration and clean cut

MATERIAL

reinforced concrete	✓✓
washed concrete	✓✓
concrete/concrete products	✓✓
brickwork/bricks	✓✓
sand-lime brick	✓
sandstone	✓
granite/natural stone	✓

ITEM NUMBER	DESCRIPTION	Ø (MM)	BORE (MM)	NUMBER OF SEGMENTS	SEGMENT THICKNESS (MM)	LIST PRICE RRP (WITHOUT VAT IN EUR)
310065	BX13	300	25,4/20	20	2,8	
311417	BX13	300	30/25,4	20	2,8	
310049	BX13	350	25,4/20	21	3,0	
310050	BX13	350	30/25,4	21	3,0	
310035	BX13	380	30	22	3,2	
310057	BX13	400	25,4/20	24	3,2	
311118	BX13	400	30/25,4	24	3,2	
310975	BX13	400	60	24	3,2	
311991	BX13	450	30/25,4	25	3,2	

SHOXX
POWER INSIDE

BX13 SILENCIO ♦♦♦♦♦

REDUCED NOISE!
NEW!



OS EN 13236 compliant

MADE IN GERMANY

LASER WELDED

ADVANTAGES

- High-End-diamond blade with SHOXX forged segments for table saws
- segment height: 13 mm
- Quiet - Noise reduced to protect users and the environment
- Efficient - Sharp and clean full cuts
- Versatile - Universal for dry and wetcutting

MATERIAL

reinforced concrete	✓✓
washed concrete	✓✓
concrete/concrete products	✓✓
brickwork/bricks	✓✓
sand-lime brick	✓
sandstone	✓
granite/natural stone	✓

SILENCIO = significant noise reduction of approx. 80% compared to the standard steel core.

ITEM NUMBER	DESCRIPTION	Ø (MM)	BORE (MM)	NUMBER OF SEGMENTS	SEGMENT THICKNESS (MM)	LIST PRICE RRP (WITHOUT VAT IN EUR)
312010	BX13 Silencio	350	30/25,4	42	3,0	
312011	BX13 Silencio	450	30/25,4	48	3,6	

MASTER

BGM ♦♦♦♦♦



OS EN 13236 compliant

MADE IN GERMANY

LASER WELDED

ADVANTAGES

- Premium-diamond blade
- segment height: 13 mm
- high life time & cut quality
- low vibration

MATERIAL

concrete/concrete products	✓✓	sand-lime brick	✓
brickwork/bricks	✓✓	sandstone	✓
reinforced concrete	✓	granite/natural stone	✓
washed concrete	✓		

ITEM NUMBER	DESCRIPTION	Ø (MM)	BORE (MM)	NUMBER OF SEGMENTS	SEGMENT THICKNESS (MM)	LIST PRICE RRP (WITHOUT VAT IN EUR)
310832	BGM	300	25,40	18	2,8	
310541	BGM	350	25,40	21	3,0	
310834	BGM	400	25,40	24	3,2	
311055	BGM	450	25,40	25	3,6	

MASTER // USM



OS[®] EN 13236 compliant



ADVANTAGES

- Premium-diamond blade
- segment height: 11 mm
- high life time and clean cut
- ideal for block saws

MATERIAL

brickwork/bricks	✓✓	extreme dense sand-lime brick	✓
reinforced concrete	✓	sand-lime brick	✓
washed concrete	✓	sandstone	✓
concrete/concrete products	✓	granite/natural stone	✓

ITEM NUMBER	DESCRIPTION	Ø (MM)	BORE (MM)	NUMBER OF SEGMENTS	SEGMENT THICKNESS (MM)	LIST PRICE RRP (WITHOUT VAT IN EUR)
311353	USM	300	30/25,4	21	2,8	
310950	USM	350	30/25,4	21	3,0	
311144	USM	350	60,00	21	3,0	
310951	USM	400	30/25,4	24	3,2	
311176	USM	400	60,00	24	3,2	
310952	USM	450	30/25,4	25	3,6	
310953	USM	500	30/25,4	30	3,6	
311185	USM	500	60,00	30	3,6	
310954	USM	600	60/25,4	34	3,6	
311072	USM	625	60/25,4	36	4,6	
311073	USM	650	60/25,4	36	4,0	
310955	USM	700	60/25,4	40	4,0	
311122	USM	800	60,00	46	4,6	
310956	USM	900	60/55	52	4,6	
311074	USM	1000	60/25,4	52	4,6	

SHOXX®

POWER INSIDE

UB13



OS[®] EN 13236 compliant



ADVANTAGES

- HighEnd-diamond blade with SHOXX forged segments
- segment height: 13 mm
- the highest life time & cutting properties
- ideal for block saws

MATERIAL

reinforced concrete	✓✓
concrete/concrete products	✓✓
extreme dense sand-lime brick	✓✓
brickwork/bricks	✓✓
sand-lime brick	✓✓
granite/natural stone	✓✓

ITEM NUMBER	DESCRIPTION	Ø (MM)	BORE (MM)	NUMBER OF SEGMENTS	SEGMENT THICKNESS (MM)	LIST PRICE RRP (WITHOUT VAT IN EUR)
310577	UB13	700	60	40	4,6	
310578	UB13	900	60/55	52	4,6	

Other diameters available.



CUTTING

CONCRETE

UNIVERSAL

SHOXX
POWER INSIDE

MX13 ♦♦♦♦♦♦♦♦



EN 13236 compliant

MADE IN GERMANY

LASER WELDED

ADVANTAGES

- HighEnd-diamond blade with SHOXX forged segments
- segment height: 13 mm
- high life time and clean cut
- particularly suitable for abrasive materials

MATERIAL

reinforced concrete	✓✓	sandstone	✓✓
concrete/concrete products	✓✓	washed concrete	✓
brickwork/bricks	✓✓		
sand-lime brick	✓✓		

ITEM NUMBER	DESCRIPTION	Ø (MM)	BORE (MM)	NUMBER OF SEGMENTS	SEGMENT THICKNESS (MM)	LIST PRICE RRP (WITHOUT VAT IN EUR)
310351	MX13	300	25,4	20	2,8	
310353	MX13	350	25,4	24	3,0	
310355	MX13	400	25,4	28	3,2	

MASTER

MST ♦♦♦♦♦♦♦♦

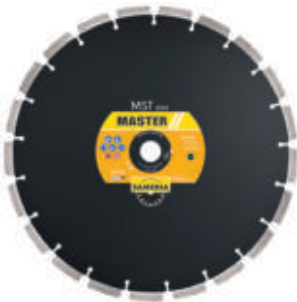

EN 13236 compliant

MADE IN GERMANY

LASER WELDED

ADVANTAGES

- Premium-diamond blade
- segment height: 11 mm
- universal range of applications

MATERIAL

concrete/concrete products	✓✓	washed concrete	✓
brickwork/bricks	✓✓	sand-lime brick	✓
reinforced concrete	✓	sandstone	✓

ITEM NUMBER	DESCRIPTION	Ø (MM)	BORE (MM)	NUMBER OF SEGMENTS	SEGMENT THICKNESS (MM)	LIST PRICE RRP (WITHOUT VAT IN EUR)
310370	MST	300	25,40	18	2,8	
310372	MST	350	25,40	21	3,0	
310374	MST	400	25,40	24	3,2	

SHOXX®

POWER INSIDE



EN 13236 compliant

MADE IN GERMANY

LASER WELDED

GX20 SILENCIO

REDUCED NOISE!

ADVANTAGES

- High-End-diamond blade with SHOXX forged segments
- segment height: 20 mm
- ideal for bridge saws
- max. noise reduction with SILENCIO steel core

MATERIAL

granite/natural stone	✓✓	limestone/travertine	✓
quartz	✓	porphyry	✓

* SILENCIO = significant noise reduction of approx. 80% compared to the standard steel core.

ITEM NUMBER	DESCRIPTION	Ø (MM)	BORE (MM)	NUMBER OF SEGMENTS	SEGMENT THICKNESS (MM)	LIST PRICE RRP (WITHOUT VAT IN EUR)
310393	GX20 SILENCIO	400	60,00	24	3,2	
310335	GX20 SILENCIO	500	60,00	30	3,8	
310385	GX20 SILENCIO	600	60,00	36	4,8	

SHOXX®

POWER INSIDE



EN 13236 compliant

MADE IN GERMANY

LASER WELDED

GX13 SILENCIO

REDUCED NOISE!

ADVANTAGES

- High-End-diamond blade with SHOXX forged segments
- segment height: 13 mm
- low vibration and clean cut
- max. noise reduction with SILENCIO steel core

MATERIAL

granite/natural stone	✓✓	reinforced concrete	✓
concrete/concrete products	✓✓	washed concrete	✓
porphyry	✓✓	quartz	✓
brickwork/bricks	✓✓	limestone/travertine	✓

ITEM NUMBER	DESCRIPTION	Ø (MM)	BORE (MM)	NUMBER OF SEGMENTS	SEGMENT THICKNESS (MM)	LIST PRICE RRP (WITHOUT VAT IN EUR)
311053	GX13 SILENCIO	300	30/25,4	18	2,8	
310084	GX13 SILENCIO	350	30/25,4	21	3,0	
310823	GX13 SILENCIO	400	30/25,4	24	3,2	
311392	GX13 SILENCIO	450	30/25,40	26	3,6	

SHOXX®

POWER INSIDE



EN 13236 compliant

MADE IN GERMANY

LASER WELDED

GX13

ADVANTAGES

- High-End-diamond blade with SHOXX forged segments
- segment height: 13 mm
- high lifetime & cut quality
- low vibration and clean cut

MATERIAL

granite/natural stone	✓✓	reinforced concrete	✓
concrete/concrete products	✓✓	washed concrete	✓
porphyry	✓✓	quartz	✓
brickwork/bricks	✓✓	limestone/travertine	✓

ITEM NUMBER	DESCRIPTION	Ø (MM)	BORE (MM)	NUMBER OF SEGMENTS	SEGMENT THICKNESS (MM)	LIST PRICE RRP (WITHOUT VAT IN EUR)
310010	GX13	300	30/25,40	18	2,8	
310278	GX13	300	40,00	18	2,8	
300108	GX13	350	25,40	21	3,0	
310009	GX13	350	30,00	21	3,0	
310383	GX13	350	60,0	21	3,0	
310821	GX13	400	25,40	24	3,2	
310822	GX13	400	30,00	24	3,2	
311369	GX13	450	60,0	15	3,6	

MASTER**GSM SILENCIO** **REDUCED NOISE!** EN 13236
compliantMADE IN
GERMANY LASER
WELDED **ADVANTAGES**

- Premium diamond blade
- segment height: 11 mm
- max. noise reduction with SILENCIO steel core
- ideal for 2,2 kW-table saws

MATERIAL

granite/natural stone	✓✓	concrete/concrete products	✓
brickwork/bricks	✓✓	quartz	✓
reinforced concrete	✓	limestone/travertine	✓
washed concrete	✓	porphyry	✓

* SILENCIO = significant noise reduction of approx.
80% compared to the standard steel core.

ITEM NUMBER	DESCRIPTION	Ø (MM)	BORE (MM)	NUMBER OF SEGMENTS	SEGMENT THICKNESS (MM)	LIST PRICE RRP (WITHOUT VAT IN EUR)
311052	GSM SILENCIO	250	30/25,4	17	2,6	
311044	GSM SILENCIO	300	30/25,4	18	2,6	
311045	GSM SILENCIO	350	30/25,4	21	3,0	
311046	GSM SILENCIO	400	30/25,4	24	3,2	
311047	GSM SILENCIO	450	25,40	26	3,6	
311048	GSM SILENCIO	500	25,40	30	4,0	
311049	GSM SILENCIO	600	25,40	36	4,6	
311050	GSM SILENCIO	700	25,40	40	4,6	
311067	GSM SILENCIO	900	60/55	52	4,6	

MASTER**GTM**  EN 13236
compliant**ADVANTAGES**

- Premium diamond blade
- segment height: 10 mm
- continuous turbo rim
- for precision cuts

MATERIAL

granite/natural stone	✓✓	concrete/concrete products	✓
quartz	✓✓	limestone/travertine	✓
brickwork/bricks	✓✓	porphyry	✓
reinforced concrete	✓	tiles	✓
washed concrete	✓	porcelain stoneware	✓

ITEM NUMBER	DESCRIPTION	Ø (MM)	BORE (MM)	NUMBER OF SEGMENTS	SEGMENT THICKNESS (MM)	LIST PRICE RRP (WITHOUT VAT IN EUR)
311226	GTM	230	30/25,4	1	2,6	
310387	GTM	300	30/25,4	1	2,8	
310388	GTM	350	30/25,4	1	2,8	

**CUTTING****GRANITE**

SHOXX®

POWER INSIDE

KSX



HIGH-END-DIAMOND BLADE

SEGMENT HEIGHT: 8 MM

SPECIAL ALLOY FOR PORCELAIN STONEWARE 2-3 CM THICK & CERAMIC COATING PANEL

VERY NARROW TOOTHING FOR A CLEAN CUT

ONLY FOR WET CUTTING!



More information

EN 13236 compliant

MATERIAL

porcelain stoneware 2-3cm	✓✓	ceramic composite panel	✓✓	limestone/travertine	✓	hard bricks	✓
porcelain stoneware	✓✓	artificial stone/marble	✓✓	porphyry	✓		
granite/natural stone	✓✓	quartz	✓	tiles	✓		

ITEM NUMBER	DESCRIPTION	Ø (MM)	BORE (MM)	NUMBER OF SEGMENTS	SEGMENT THICKNESS (MM)	LIST PRICE RRP (WITHOUT VAT IN EUR)
310441	KSX	180	30/25,4	14	2,0	
310442	KSX	200	30/25,4	16	2,0	
310443	KSX	230	30/25,4	18	2,0	
310444	KSX	250	30/25,4	20	2,2	
310445	KSX	300	30/25,4	24	2,4	
310446	KSX	350	30/25,4	28	2,4	
310588	KSX	400	30/25,4	32	2,8	
310970	KSX	400	60,00	32	2,8	
311071	KSX	500	30/25,4	36	3,4	



CUTTING

TILES



KVX



 EN 13236 compliant

ADVANTAGES

- High-End-diamond blade
- segment height: 8 mm
- can be used dry and wet
- extremely clean cutting edges

MATERIAL

porcelain stoneware	✓✓
tiles	✓✓
granite/natural stone	✓

ITEM NUMBER	DESCRIPTION	Ø (MM)	BORE (MM)	NUMBER OF SEGMENTS	SEGMENT THICKNESS (MM)	LIST PRICE RRP (WITHOUT VAT IN EUR)
311078	KVX	150	25,4/22,23	1	1,6	
311079	KVX	180	30/25,4	1	1,6	
311080	KVX	200	30/25,4	1	1,6	
311092	KVX	230	30/25,4	1	1,6	
311082	KVX	250	30/25,4	1	1,6	
311083	KVX	300	30/25,4	1	2,0	
311084	KVX	350	30/25,4	1	2,0	

MASTER

KCM



 EN 13236 compliant

ADVANTAGES

- Premium diamond blade
- segment height: 7 mm
- continuous rim
- clean cut

MATERIAL

porcelain stoneware	✓✓	artificial stone/marble	✓
tiles	✓✓	hard bricks	✓
porcelain stoneware 2-3cm	✓	ceramic composite panel	✓
granite/natural stone	✓		

ITEM NUMBER	DESCRIPTION	Ø (MM)	BORE (MM)	NUMBER OF SEGMENTS	SEGMENT THICKNESS (MM)	LIST PRICE RRP (WITHOUT VAT IN EUR)
310015	KCM	150	25,4/22,23	1	1,5	
300003	KCM	180	30/25,4	1	1,6	
300004	KCM	200	30/25,4	1	1,6	
310283	KCM	230	30/25,4	1	1,6	
300006	KCM	250	30/25,4	1	1,6	
300007	KCM	300	30/25,4	1	2,0	
300053	KCM	350	30/25,4	1	2,0	

MASTER // KJM

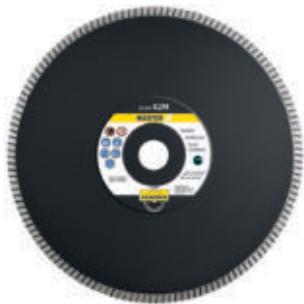

 EN 13236 compliant

ADVANTAGES

- Premium diamond blade
- segment height: 7 mm
- with reinforced flange (up to Ø 230 mm)
- extra thin turbo rim
- quick & clean cut

MATERIAL

tiles	✓✓
ceramic composite panel	✓✓
porcelain stoneware 2-3cm	✓
porcelain stoneware	✓
granite/natural stone	✓
artificial stone/marble	✓

ITEM NUMBER	DESCRIPTION	Ø (MM)	BORE (MM)	NUMBER OF SEGMENTS	SEGMENT THICKNESS (MM)	LIST PRICE RRP (WITHOUT VAT IN EUR)
310628	KJM	150	25,40	1	1,4	
311224	KJM	180	22,23	1	1,6	
310629	KJM	180	25,40	1	1,6	
330023	KJM	200	30/25,4	1	1,6	
310630	KJM	230	22,23	1	1,6	
310631	KJM	250	30/25,4	1	1,6	
310632	KJM	300	30/25,4	1	2,2	
310358	KJM	350	30/25,4	1	2,2	

TECHNIC // KCT



EN 13236 compliant

ADVANTAGES

- Professional diamond blade
- segment height: 7 mm
- continuous rim
- clean cut
- not suitable for porcelain stoneware and hard tiles

MATERIAL

tiles	✓✓
-------	----

ITEM NUMBER	DESCRIPTION	Ø (MM)	BORE (MM)	NUMBER OF SEGMENTS	SEGMENT THICKNESS (MM)	LIST PRICE RRP (WITHOUT VAT IN EUR)
330008	KCT	115	22,23	1	1,6	
330009	KCT	125	22,23	1	1,6	
330010	KCT	180	30/25,4	1	2,0	
330011	KCT	200	30/25,4	1	2,0	
330012	KCT	230	22,23	1	2,0	



CUTTING

TILES

SPECIAL



KX13 SILENCIO

REDUCED NOISE!



EN 13236 compliant

MADE IN GERMANY

LASER WELDED

ADVANTAGES

- High-End-diamond blade with SHOXX forged segments
- segment height: 13 mm
- max. noise reduction with SILENCIO steel core
- for hard bricks, clinker
- particularly suitable for 2.2 kW table saws

MATERIAL

hard bricks	✓✓	sandstone	✓✓
concrete/concrete products	✓✓	washed concrete	✓
brickwork/bricks	✓✓	reinforced concrete	✓
sand-lime brick	✓✓	extreme dense sand-lime brick	✓

* SILENCIO = significant noise reduction of approx. 80% compared to the standard steel core.

ITEM NUMBER	DESCRIPTION	Ø (MM)	BORE (MM)	NUMBER OF SEGMENTS	SEGMENT THICKNESS (MM)	LIST PRICE RRP (WITHOUT VAT IN EUR)
310092	KX13 SILENCIO	300	25,40	20	2,8	
310093	KX13 SILENCIO	350	30/25,4	24	3,0	



KX13



EN 13236 compliant

MADE IN GERMANY

LASER WELDED

ADVANTAGES

- High-End-diamond blade with SHOXX forged segments
- segment height: 13 mm
- for hard bricks, clinker

MATERIAL

hard bricks	✓✓	sandstone	✓✓
concrete/concrete products	✓✓	washed concrete	✓
brickwork/bricks	✓✓	reinforced concrete	✓
sand-lime brick	✓✓	extreme dense sand-lime brick	✓

ITEM NUMBER	DESCRIPTION	Ø (MM)	BORE (MM)	NUMBER OF SEGMENTS	SEGMENT THICKNESS (MM)	LIST PRICE RRP (WITHOUT VAT IN EUR)
310088	KX13	300	25,40	18	2,8	
310089	KX13	350	30/25,4	21	3,0	
310144*	KX13	350	30/25,40	36	3,0	
310535	KX13	400	25,40	24	3,0	

* SHOXX KX13/K 350x25,4 with short segments

RECOMMENDATION TABLE FLOOR SAWS

MATERIAL	CONCRETE					UNI.	ASPHALT			SPECIAL			
	UX17	BY13	BCM	BFM	MY13	AX13	ASM	AST	TX13	RFM	FSM	FSA	FQM/FQY/FQA
	SHOXX		MASTER		SHOXX	SHOXX	MASTER	TECHNIC	SHOXX		MASTER		
machines (kW)	< 15	< 7,5	< 7,5	< 15	< 7,5	< 15	< 15	< 7,5	< 7,5	< 15	< 25	< 25	
segment height	17	13	13	11	13	13	11	11	13	10	11	9	10
diameter (mm)	350-600	350-450	350-450	450-800	350-400	350-600	350-800	350-500	350-450	350	350-400	350-400	120
page	58	58	59	59	59	60	61	61	62	62	62	63	63
reinforced old concrete	✓✓	✓✓	✓✓	✓✓	✓✓			✓	✓				✓✓
asphalt						✓✓	✓✓	✓✓	✓	✓✓			
green concrete until 24h											✓✓		
green concrete 24h - 48h												✓✓	
screed													✓✓



SHOXX[®] POWER INSIDE

UX17



EN 13236
compliant

MADE IN
GERMANY

LASER
WELED

ADVANTAGES

- High-End-diamond blade with SHOXX forged segments
- segment height: 17 mm
- the highest life time & cutting properties
- low vibration and clean cut
- maximum versatility
- for floor saws up to 15 kW

MATERIAL

reinforced old concrete ✓✓

ITEM NUMBER	DESCRIPTION	Ø (MM)	BORE (MM)	NUMBER OF SEGMENTS	SEGMENT THICKNESS (MM)	LIST PRICE RRP (WITHOUT VAT IN EUR)
310141	UX17	350	25,4	22	3,0	
310201	UX17	400	25,4	25	3,2	
311054	UX17	450	25,4	25	3,6	
312041	UX17	500	25,4	30	3,6	
311992	UX17	600	25,4	34	3,6	

Other diameters available!

SHOXX[®] POWER INSIDE

BX13



EN 13236
compliant

MADE IN
GERMANY

LASER
WELED

ADVANTAGES

- High-End-diamond blade with SHOXX forged segments
- segment height: 13 mm
- the highest life time & cutting properties
- low vibration and clean cut
- for floor saws up to 7,5 kW

MATERIAL

reinforced old concrete ✓✓

ITEM NUMBER	DESCRIPTION	Ø (MM)	BORE (MM)	NUMBER OF SEGMENTS	SEGMENT THICKNESS (MM)	LIST PRICE RRP (WITHOUT VAT IN EUR)
310049	BX13	350	25,4/20	21	3,0	
310050	BX13	350	30/25,4	21	3,0	
310057	BX13	400	25,4/20	24	3,2	
310220	BX13	450	25,40	25	3,6	

Other diameters available!



CUTTING

CONCRETE

UNIVERSAL

MASTER BGM



 EN 13236 compliant

MADE IN GERMANY 

LASER WELDED 

ADVANTAGES

- Premium diamond blade
- segment height: 13 mm
- high life time & cut quality
- low vibration
- for floor saws up to 7,5 kW

MATERIAL

reinforced old concrete 

ITEM NUMBER	DESCRIPTION	Ø (MM)	BORE (MM)	NUMBER OF SEGMENTS	SEGMENT THICKNESS (MM)	LIST PRICE RRP (WITHOUT VAT IN EUR)
310541	BGM	350	25,40	21	3,0	
310834	BGM	400	25,40	24	3,2	
311055	BGM	450	30/25,40	25	3,6	

MASTER BFM



 EN 13236 compliant

MADE IN GERMANY 

LASER WELDED 

ADVANTAGES

- Premium diamond blade
- segment height: 11 mm
- for floor saws up to 15 kW

MATERIAL

reinforced old concrete 

ITEM NUMBER	DESCRIPTION	Ø (MM)	BORE (MM)	NUMBER OF SEGMENTS	SEGMENT THICKNESS (MM)	LIST PRICE RRP (WITHOUT VAT IN EUR)
310971	BFM	450	25,40	25	3,6	
310972	BFM	500	25,40	30	3,6	
310078	BFM	600	25,40	34	3,6	
311920	BFM	600	60,00	34	3,6	
310929	BFM	650	25,40	36	3,6	
310079	BFM	700	25,40	40	3,6	
310080	BFM	800	25,40	45	3,6	

SHOXX MX13



 EN 13236 compliant

MADE IN GERMANY 

LASER WELDED 

ADVANTAGES

- HighEnd-diamond blade with SHOXX forged segments
- segment height: 13 mm
- high life time and clean cut
- particularly suitable for abrasive materials
- for floor saws up to 7,5 kW

MATERIAL

reinforced old concrete 

ITEM NUMBER	DESCRIPTION	Ø (MM)	BORE (MM)	NUMBER OF SEGMENTS	SEGMENT THICKNESS (MM)	LIST PRICE RRP (WITHOUT VAT IN EUR)
310353	MX13	350	25,4	24	3,0	
310355	MX13	400	25,4	28	3,2	

SHOXX®

POWER INSIDE

AX13



**HIGH-END-
DIAMOND BLADE**

WITH **SHOXX**
FORGED SEGMENTS

SEGMENT HEIGHT:
13 MM

HIGH LIFETIME

**DEEP PROTECTION
SEGMENTS**

LOW VIBRATION

IDEAL FOR **CUT-OFF
PETROL SAW, FLOOR
SAWS UP TO 25 KW**



More information

MADE IN GERMANY LASER WELDED EN 13236 compliant

ITEM NUMBER	DESCRIPTION	Ø (MM)	BORE (MM)	NUMBER OF SEGMENTS	SEGMENT THICKNESS (MM)	LIST PRICE RRP (WITHOUT VAT IN EUR)
310339	AX13	350	25,4	21	3,0	
310341	AX13	400	25,4	24	3,2	
310342	AX13	450	25,4	25	3,6	
310343	AX13	500	25,4	30	3,6	
310344	AX13	600	25,4	35	4,0	

MATERIAL

asphalt



MASTER // ASM



 EN 13236
compliant

MADE IN
GERMANY 

LASER
WELDED 

ADVANTAGES

- Premium diamond blade
- segment height: 11 mm
- DEEP protection segments
- ideal for cut-off petrol saw, floor saws up to 25 kW

MATERIAL

asphalt  

ITEM NUMBER	DESCRIPTION	Ø (MM)	BORE (MM)	NUMBER OF SEGMENTS	SEGMENT THICKNESS (MM)	LIST PRICE RRP (WITHOUT VAT IN EUR)
300045	ASM	350	25,4	21	3,0	
300046	ASM	400	25,4	24	3,2	
300087	ASM	450	25,4	25	3,6	
310129	ASM	500	25,4	30	3,6	
310130	ASM	600	25,4	35	4,0	
310029	ASM	700	25,4	40	4,6	
310031	ASM	800	25,4	50	4,6	

TECHNIC // AST



 EN 13236
compliant

MADE IN
GERMANY 

LASER
WELDED 

ADVANTAGES

- Professional diamond blade
- segment height: 11 mm
- DEEP protection segments
- ideal for cut-off petrol saw and floor saws up to 7.5 kW

MATERIAL

asphalt  

Reinforced old concrete 

ITEM NUMBER	DESCRIPTION	Ø (MM)	BORE (MM)	NUMBER OF SEGMENTS	SEGMENT THICKNESS (MM)	LIST PRICE RRP (WITHOUT VAT IN EUR)
310076	AST	350	25,4/20	21	3,0	
310072	AST	400	25,40	24	3,2	
310077	AST	450	25,40	25	3,6	
310118	AST	500	25,40	30	3,6	



CUTTING

ASPHALT

SHOXX
POWER INSIDE

TX13 ♦♦♦♦♦♦♦♦



EN 13236 compliant

MADE IN GERMANY

LASER WELDED

ADVANTAGES

- HighEnd-diamond blade
- with SHOXX forged segments
- segment height: 13 mm
- low vibration and clean cut
- the universal blade for construction
- 3 segment types - application categories (concrete/asphalt)

MATERIAL

- Reinforced old concrete ✓
- asphalt ✓

ITEM NUMBER	DESCRIPTION	Ø (MM)	BORE (MM)	NUMBER OF SEGMENTS	SEGMENT THICKNESS (MM)	LIST PRICE RRP (WITHOUT VAT IN EUR)
310905	TX13	350	25,4/20	21	3,0	
310915	TX13	400	25,4/20	24	3,2	
310916	TX13	450	25,40	25	3,6	

MASTER

RFM ♦♦♦♦♦♦♦♦



EN 13236 compliant

MADE IN GERMANY

LASER WELDED

ADVANTAGES

- Premium milling wheel for crack/joint widening
- segment height: 10 mm
- special alloy for asphalt and concrete
- for floor saws up to 25 kW

MATERIAL

- asphalt ✓✓

ITEM NUMBER	DESCRIPTION	Ø (MM)	BORE (MM)	NUMBER OF SEGMENTS	SEGMENT THICKNESS (MM)	LIST PRICE RRP (WITHOUT VAT IN EUR)
310633	RFM	350	25,40	21	8,0	
310521	RFM	350	25,40	21	10,0	

MASTER

FSM ♦♦♦♦♦♦♦♦



EN 13236 compliant

MADE IN GERMANY

LASER WELDED

ADVANTAGES

- Premium green concrete blade up to 24 h.
- segment height: 11 mm
- with brazed TIP-Segments for steel core protection
- for floor saws up to 25 kW

MATERIAL

- green concrete up to 24h ✓✓

ITEM NUMBER	DESCRIPTION	Ø (MM)	BORE (MM)	NUMBER OF SEGMENTS	SEGMENT THICKNESS (MM)	LIST PRICE RRP (WITHOUT VAT IN EUR)
310030	FSM	350	25,40	24	3,2	
310273	FSM	400	25,40	28	3,2	

MASTER // FSA



 EN 13236
compliant



MADE IN
GERMANY 

LASER
WELDED 

ADVANTAGES

- Premium green concrete blade up to 24 h
- segment height: 9 mm
- with brazed TIP-Segments for steel core protection
- for floor saws up to 25 kW

MATERIAL

green concrete 24h-48h  

ITEM NUMBER	DESCRIPTION	Ø (MM)	BORE (MM)	NUMBER OF SEGMENTS	SEGMENT THICKNESS (MM)	LIST PRICE RRP (WITHOUT VAT IN EUR)
310403	FSA	350	25,40	24	2,8	
310301	FSA	400	25,40	28	3,2	

MASTER // FQM/FQX/FQA



 EN 13236
compliant

ADVANTAGES

- premium Ø120 mm diamond milling discs for laying under-floor heating pipes with a diameter of 14 or 16 mm
- segment height: 10 mm

MATERIAL

- **FQM (red):**
suitable for hard concrete
- **FQX (green):**
suitable for medium-hard concrete and screed
- **FQA (black):**
suitable for abrasive concrete and screed

Reinforced old concrete  

screed  

ITEM NUMBER	DESCRIPTION	Ø (MM)	BORE (MM)	NUMBER OF SEGMENTS	SEGMENT THICKNESS (MM)	LIST PRICE RRP (WITHOUT VAT IN EUR)
311729	FQM	120	22,23	14	16,2	
311730	FQM	120	22,23	16	17,3	
311727	FQX	120	22,23	14	16,2	
311728	FQX	120	22,23	16	17,3	
311731	FQA	120	22,23	14	16,2	
311732	FQA	120	22,23	16	17,3	



CUTTING

SPECIAL

RECOMMENDATION TABLE WALL CHASER

MATERIAL	UNIVERSAL							SPECIAL	
	MX13 MSF	MST	MIT	MSE	MES	TPM	TPT	MST-B/LF/P	MT-LF/P-L
segment height	13	11	10	12	10	9	10	11	10
diameter (mm)	115-180	125-180	125-180	125-180	115-125	115-125	115-125	150-180	150-180
page	64	65	65	65	66	66	66	67	67
reinforced concrete	✓✓	✓	✓						
extreme dense sand-lime brick	✓✓								
brickwork/bricks	✓	✓✓	✓✓	✓✓	✓	✓✓	✓	✓✓	✓✓
sand-lime brick		✓✓	✓✓	✓					
hard cement joints						✓✓	✓		
abrasive cement joints						✓✓	✓		
shell limestone						✓✓			
concrete								✓✓	✓✓
concrete products								✓✓	✓✓
plaster								✓✓	✓✓
cement and mortar joints								✓✓	✓✓



MX13 MSF



HIGH-END-DIAMOND BLADE

WITH SHOXX FORGED SEGMENTS

SEGMENT HEIGHT: 13 MM

MSF-MX13:
WITH REDUCED NUMBER OF SEGMENTS –
IDEAL UP TO 2 KW;
ESPECIALLY GOOD FOR LIMESTONE & REINFORCED CONCRETE

MX13: IDEAL UP TO 2KW



ITEM NUMBER	DESCRIPTION	Ø (MM)	BORE (MM)	NUMBER OF SEGMENTS	SEGMENT THICKNESS (MM)	LIST PRICE RRP (WITHOUT VAT IN EUR)
310345	MX13	115	22,23	8	2,4	
311638	MSF-MX13	125	22,23	8	2,4	
310346	MX13	125	22,23	9	2,6	
310617	MX13	140	22,23	10	2,6	
310514	MX13	140	30,0	10	2,6	
311762	MSF-MX13	150	22,23	9	2,4	
310347	MX13	150	22,23	11	2,6	
310348	MX13	180	22,23	13	2,4	
312031	MSF-MX13	180	30,0	10	2,4	

MATERIAL

reinforced concrete	✓✓
extreme dense sand-lime brick	✓✓
brickwork/bricks	✓

MASTER // MST



 EN 13236 compliant

MADE IN GERMANY 

LASER WELDED 

ADVANTAGES

- Premium-diamond blade
- segment height: 11 mm
- universal range of applications
- for wall chaser more than 2 kW

MATERIAL

reinforced concrete	✓
brickwork / bricks	✓✓
sand-lime brick	✓✓

ITEM NUMBER	DESCRIPTION	Ø (MM)	BORE (MM)	NUMBER OF SEGMENTS	SEGMENT THICKNESS (MM)	LIST PRICE RRP (WITHOUT VAT IN EUR)
300055	MST	125	22,23	8	2,4	
310045	MST	150	22,23	11	2,4	
310368	MST	180	22,23	12	2,4	

MASTER // MTT



 EN 13236 compliant

ADVANTAGES

- Premium diamond blade
- segment height: 10 mm
- continuous turbo rim
- for wall chaser more than 2 kW

MATERIAL

reinforced concrete	✓
brickwork / bricks	✓✓
sand-lime brick	✓✓

ITEM NUMBER	DESCRIPTION	Ø (MM)	BORE (MM)	NUMBER OF SEGMENTS	SEGMENT THICKNESS (MM)	LIST PRICE RRP (WITHOUT VAT IN EUR)
300011	MTT	125	22,23	1	2,2	
310046	MTT	150	22,23	1	2,2	
311059	MTT	180	22,23	1	2,6	

TECHNIC // MSE



 EN 13236 konform

ADVANTAGES

- Professional diamond blade
- segment height: 12 mm

MATERIAL

brickwork / bricks	✓✓
sand-lime brick	✓

ITEM NUMBER	DESCRIPTION	Ø (MM)	BORE (MM)	NUMBER OF SEGMENTS	SEGMENT THICKNESS (MM)	LIST PRICE RRP (WITHOUT VAT IN EUR)
310020	MSE	125	22,23	9	2,4	
310073	MSE	150	22,23	10	2,6	
310028	MES	180	22,23	14	2,6	



CUTTING

UNIVERSAL

TECHNIC // MES



 EN 13236 compliant

ADVANTAGES

- Professional diamond blade
- segment height: 10 mm
- universal for construction site
- with packing unit 10 (supplied in cardboard box)



MATERIAL

brickwork / bricks 

ITEM NUMBER	DESCRIPTION	Ø (MM)	BORE (MM)	NUMBER OF SEGMENTS	SEGMENT THICKNESS (MM)	LIST PRICE RRP (WITHOUT VAT IN EUR)
310582	MES	115	22,23	9	1,8	
310583	MES	125	22,23	10	1,8	

MASTER // TPM

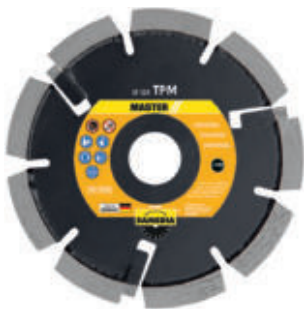

 EN 13236 compliant

MADE IN GERMANY 

LASER WELDED 

ADVANTAGES

- Premium diamond mortar raker
- segment height: 9 mm
- for joint and slot cutting, 6 and 8 mm cut width
- optimum steel core protection from brazed protection segments
- very high lifetime

MATERIAL

brickwork / bricks 

hard cement joints 

abrasive cement joints 

shell limestone 

ITEM NUMBER	DESCRIPTION	Ø (MM)	BORE (MM)	NUMBER OF SEGMENTS	SEGMENT THICKNESS (MM)	LIST PRICE RRP (WITHOUT VAT IN EUR)
310227	TPM	115	22,23	8	6,0	
310470	TPM	115	22,23	8	8,0	
310180	TPM	125	22,23	8	6,0	
310453	TPM	125	22,23	8	8,0	

TECHNIC // TPT



 EN 13236 compliant

LASER WELDED 

ADVANTAGES

- Profi-Diamantfräse
- segment height: 10 mm
- for joint and slot cutting, 6, 4 and 10 mm cut width

MATERIAL

brickwork / bricks 

hard cement joints 

abrasive cement joints 

ITEM NUMBER	DESCRIPTION	Ø (MM)	BORE (MM)	NUMBER OF SEGMENTS	SEGMENT THICKNESS (MM)	LIST PRICE RRP (WITHOUT VAT IN EUR)
310252	TPT	115	22,23	9	6,4	
311387	TPT	115	22,23	10	10,0	
310253	TPT	125	22,23	10	6,4	
311388	TPT	125	22,23	12	10,0	

MASTER**MST-B / MST-L/F / MST-P
MST-L****ADVANTAGES**

- Premium diamond blade
- segment height: 11 mm
- MST-B (Art.-Nr. 310639):
matches for BEPo construction cutter;
for nearly flush plunge cuts up to 45 mm deep
- MST-L/F (Art.-Nr. 310745):
matches for "Lamello" or "Fein" shadow joint cutters;
for nearly flush plunge cuts up to
60 mm deep
- MST-P (Art.-Nr. 311485 + 311484):
matches for POPP construction cutter; for nearly
flush plunge cuts up to 47 mm (150x23,5) or
62mm (180mmx23,5) deep

MATERIAL

brickwork / bricks	✓✓
concrete	✓✓
concrete products	✓✓
plaster	✓✓
cement and motar joints	✓✓

ITEM NUMBER	DESCRIPTION	Ø (MM)	BORE (MM)	NUMBER OF SEGMENTS	SEGMENT THICKNESS (MM)	LIST PRICE RRP (WITHOUT VAT IN EUR)
310639	MST-B	150	26,00	11	2,4	
310745	MST-L/F	180	22,23	12	2,4	
311485	MST-P	150	23,50	11	2,4	
311484	MST-P	180	23,50	12	2,4	
311849	MST-L-TANGA	180	29,00	12	2,4	

MASTER**MTT-L/F / MTT-P / MTT-L****ADVANTAGES**

- Premium diamond blade
for almost flush plunge cuts
- segment height: 10 mm
- MTT-L/F (Art.-Nr. 310746):
suitable for LAMELLO or FEIN assembly milling machines;
for nearly flush plunge cuts up to 60 mm deep
- MTT-P (Art.-Nr. 310891 + 311483):
suitable for POPP assembly cutters
for nearly flush plunge cuts up to 47mm
(150x23,5) or 62mm (180mmx23,5) deep
- MTT-L-TANGA (Art.-Nr. 311705):
suitable for LAMELLO-TANGA assembly milling
for almost flush plunge cuts

MATERIAL

brickwork / bricks	✓✓
concrete	✓✓
concrete products	✓✓
plaster	✓✓
cement and motar joints	✓✓

ITEM NUMBER	DESCRIPTION	Ø (MM)	BORE (MM)	NUMBER OF SEGMENTS	SEGMENT THICKNESS (MM)	LIST PRICE RRP (WITHOUT VAT IN EUR)
310746	MTT-L/F	180	22,23	1	2,6	
310891	MTT-P	150	23,50	1	2,2	
311483	MTT-P	180	23,50	1	2,6	
311705	MTT-L-TANGA	180	29,00	1	2,6	

**CUTTING**

UNIVERSAL

SPECIAL

SHOXX®

POWER INSIDE

WBX

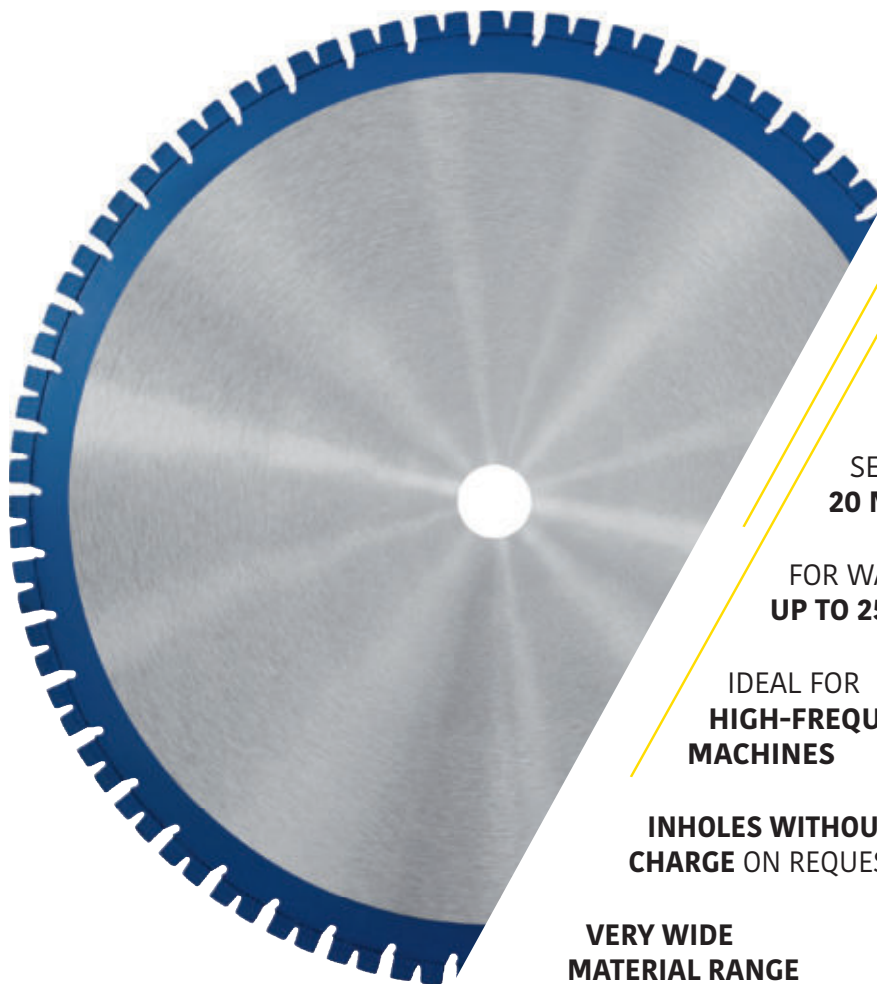

**HIGHEND-
WALL SAW BLADE**

WITH **SHOXX**
FORGED SEGMENTS

SEGMENT HEIGHT:
20 MM

FOR WALL SAWS
UP TO 25 KW

IDEAL FOR
**HIGH-FREQUENCY
MACHINES**

**INHOLE WITHOUT
CHARGE ON REQUEST**

**VERY WIDE
MATERIAL RANGE**



More information



ITEM NUMBER	DESCRIPTION	Ø (MM)	BORE (MM)	NUMBER OF SEGMENTS	SEGMENT THICKNESS (MM)	LIST PRICE RRP (WITHOUT VAT IN EUR)
310094	WBX	600	60,00	36	4,8	
310095	WBX	650	60,00	38	4,8	
310096	WBX	800	60,00	46	4,8	
310097	WBX	900	60,00	52	4,8	
310098	WBX	1000	60,00	52	4,5	
310099	WBX	1200	60,00	62	4,5	

MATERIAL

reinforced concrete





CUTTING

CONCRETE



WLX

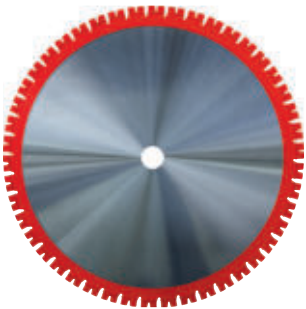

 EN 13236 compliant

MADE IN GERMANY 

LASER WELDED 

ADVANTAGES

- easy cutting bond for wall saws up to 15 kW, especially small wall saws
- segment height: 20 mm
- also for strong wall saws suitable for hard concrete aggregates
- Twin step segments for optimal cutting guidance universal use

MATERIAL

reinforced concrete 

ITEM NUMBER	DESCRIPTION	Ø (MM)	BORE (MM)	NUMBER OF SEGMENTS	SEGMENT THICKNESS (MM)	LIST PRICE RRP (WITHOUT VAT IN EUR)
310266	WLX	500	25,4	30	3,8/3,6	
310263	WLX	600	25,4	36	3,8/3,6	
310267	WLX	750	25,4	44	3,8/3,6	
310268	WLX	800	25,4	46	3,8/3,6	



WTX

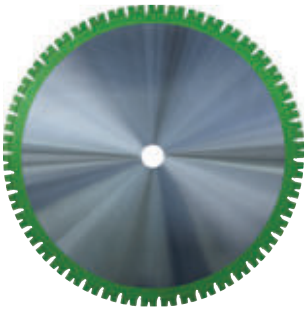

 EN 13236 compliant

MADE IN GERMANY 

LASER WELDED 

ADVANTAGES

- for wall saws up to 20 kW, easy cutting specification
- segment height: 20 mm
- Turbo twin segments
- universal use

MATERIAL

reinforced concrete 

ITEM NUMBER	DESCRIPTION	Ø (MM)	BORE (MM)	NUMBER OF SEGMENTS	SEGMENT THICKNESS (MM)	LIST PRICE RRP (WITHOUT VAT IN EUR)
311612	WTX	650	60,0	38	5,0	
311680	WTX	825	60,0	46	4,6	
311681	WTX	1000	60,0	58	4,4	
311682	WTX	1200	60,0	62	4,4	

SHOXX

POWER INSIDE

WFX 

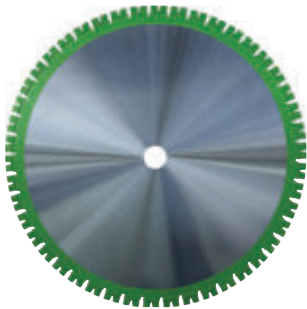

 EN 13236 compliant

MADE IN GERMANY 

LASER WELDED 

ADVANTAGES

- lifetime-oriented bond for wall saws up to 35 kW, especially with hard and abrasive concrete aggregates
- segment height: 20 mm
- highest diamond concentration
- particularly good for strong reinforcements and hard concrete

MATERIAL

reinforced concrete 

ITEM NUMBER	DESCRIPTION	Ø (MM)	BORE (MM)	NUMBER OF SEGMENTS	SEGMENT THICKNESS (MM)	LIST PRICE RRP (WITHOUT VAT IN EUR)
310100	WFX	600	60,0	36	4,8	
310101	WFX	650	60,0	38	4,8	
310102	WFX	800	60,0	46	4,8	
310104	WFX	1000	60,0	52	4,5	
310105	WFX	1200	60,0	62	4,5	

MASTER

WHM 

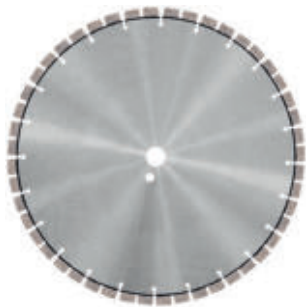

 EN 13236 compliant

MADE IN GERMANY 

LASER WELDED 

ADVANTAGES

- Premium diamond blade
- segment height: 12 mm
- short segments technic
- ideal for wet cutting engine power up to max. 10 kW:
 - freehand wall saws (e.g. RIBEMA or CARAT W3714)
 - freehand cut-off saw (e.g. Weka ANNA)
 - light 1 man electric wall saws (e.g. Demko Gamma)

MATERIAL

reinforced concrete 

brickwork 

ITEM NUMBER	DESCRIPTION	Ø (MM)	BORE (MM)	NUMBER OF SEGMENTS	SEGMENT THICKNESS (MM)	LIST PRICE RRP (WITHOUT VAT IN EUR)
311684	WHM	300	15,875	36	2,8	
311685	WHM	350	15,875	42	2,8	
311609	WHM	370	30,00	36	2,8	
311695	WHM	400	15,875	48	2,8	
311722	WHM	400	25,40	48	2,8	
311664	WHM	450	25,40	50	2,8	
311696	WHM	500	30,00	60	2,8	
311697	WHM	550	30,00	64	2,8	



ADVANTAGES

- HighEnd wet core bit with roof top turbo segments
- segment height: 10 (Ø32,42) / 12 mm
- laser welded up to Ø250 mm
- working length 450 mm
- universal & high lifetime
- ideal for coring & contracting companies
- to be used with drill stand

MATERIAL

concrete	✓✓
reinforced concrete	✓✓
sand-lime brick	✓✓
brickwork/bricks	✓✓

ITEM NUMBER	DESCRIPTION	Ø (MM)	ADAPTOR (MM)	NUMBERS OF SEGMENTS	SEGMENT THICKNESS (MM)	LIST PRICE RRP (WITHOUT VAT IN EUR)
340407	DBX	32	1 1/4" UNC	4	3,0	
340406	DBX	42	1 1/4" UNC	5	3,0	
340100	DBX	52	1 1/4" UNC	5	3,5	
340084	DBX	62	1 1/4" UNC	6	3,5	
340101	DBX	72	1 1/4" UNC	6	3,5	
340081	DBX	82	1 1/4" UNC	7	3,5	
340102	DBX	92	1 1/4" UNC	8	3,5	
340103	DBX	102	1 1/4" UNC	8	3,5	
340405	DBX	107	1 1/4" UNC	9	3,5	
340104	DBX	112	1 1/4" UNC	9	3,5	
340099	DBX	117	1 1/4" UNC	9	3,5	
340082	DBX	122	1 1/4" UNC	10	3,5	
340105	DBX	132	1 1/4" UNC	11	3,5	
340106	DBX	138	1 1/4" UNC	11	3,5	
340107	DBX	142	1 1/4" UNC	11	3,5	
340108	DBX	152	1 1/4" UNC	12	4,0	
340443	DBX	155	1 1/4" UNC	12	4,0	
340109	DBX	162	1 1/4" UNC	12	4,0	
340110	DBX	172	1 1/4" UNC	12	4,0	
340111	DBX	182	1 1/4" UNC	13	4,0	
340404	DBX	186	1 1/4" UNC	14	4,0	
340112	DBX	192	1 1/4" UNC	14	4,0	
340113	DBX	202	1 1/4" UNC	14	4,0	
340114	DBX	225	1 1/4" UNC	15	4,0	
340115	DBX	250	1 1/4" UNC	16	4,6	
340408	DBX	270	1 1/4" UNC	17	4,6	
340409	DBX	276	1 1/4" UNC	17	4,6	
340116	DBX	300	1 1/4" UNC	20	4,6	
340117	DBX	325	1 1/4" UNC	21	4,6	
340410	DBX	341	1 1/4" UNC	22	4,6	
340118	DBX	350	1 1/4" UNC	22	4,6	
340119	DBX	400	1 1/4" UNC	23	5,0	

Other working lengths and diameters available on request

MASTER

DBK 



ADVANTAGES

- Premium wet core drill for fast cutting
- segment height: 10 mm
- laser welded up to Ø250 mm
- can be used wet and dry
- working length 450 mm
- optimum drilling properties thanks to TURBO ROOF TOP segment
- ideal for operations with drill stand

MATERIAL

concrete	✓✓
reinforced concrete	✓✓
sand-lime brick	✓✓
brickwork/bricks	✓✓
granite	✓
hard stone	✓

ITEM NUMBER	DESCRIPTION	Ø (MM)	ADAPTOR (MM)	NUMBERS OF SEGMENTS	SEGMENT THICKNESS(MM)	LIST PRICE RRP (WITHOUT VAT IN EUR)
340007	DBK	32	1 1/4" UNC	4	3,0	
340437	DBK	35	1 1/4" UNC	5	3,0	
340493	DBK	38	1 1/4" UNC	5	3,0	
340008	DBK	42	1 1/4" UNC	5	3,0	
340009	DBK	52	1 1/4" UNC	5	3,5	
340496	DBK	57	1 1/4" UNC	5	3,5	
340005	DBK	62	1 1/4" UNC	5	3,5	
340411	DBK	67	1 1/4" UNC	6	3,5	
340001	DBK	72	1 1/4" UNC	6	3,5	
340494	DBK	76	1 1/4" UNC	7	3,5	
340006	DBK	82	1 1/4" UNC	7	3,5	
340010	DBK	92	1 1/4" UNC	7	3,5	
340002	DBK	102	1 1/4" UNC	8	3,5	
340121	DBK	107	1 1/4" UNC	8	3,5	
340004	DBK	112	1 1/4" UNC	9	3,5	
340022	DBK	117	1 1/4" UNC	9	3,5	
340011	DBK	122	1 1/4" UNC	10	3,5	
340323	DBK	127	1 1/4" UNC	10	3,5	
340003	DBK	132	1 1/4" UNC	10	3,5	
340053	DBK	138	1 1/4" UNC	10	3,5	
340012	DBK	142	1 1/4" UNC	11	3,5	
340013	DBK	152	1 1/4" UNC	12	4,0	
340014	DBK	162	1 1/4" UNC	12	4,0	
340015	DBK	172	1 1/4" UNC	13	4,0	
340016	DBK	182	1 1/4" UNC	14	4,0	
340057	DBK	186	1 1/4" UNC	14	4,0	
340017	DBK	192	1 1/4" UNC	14	4,0	
340018	DBK	202	1 1/4" UNC	14	4,6	
340019	DBK	225	1 1/4" UNC	15	4,6	
340020	DBK	250	1 1/4" UNC	16	4,6	
340122	DBK	270	1 1/4" UNC	17	4,6	
340316	DBK	276	1 1/4" UNC	19	4,6	
340021	DBK	300	1 1/4" UNC	19	4,6	
340023	DBK	325	1 1/4" UNC	20	4,6	
340317	DBK	341	1 1/4" UNC	22	4,6	
340152	DBK	350	1 1/4" UNC	22	4,6	
340213	DBK	400	1 1/4" UNC	23	5,0	

Other working lengths and diameters available on request



CORING/DRILLING

CONCRETE

MASTER DBK-S



ADVANTAGES

- Premium wet core drill
- Crown segment height: 10 mm
- working length 150 mm
- optimum drilling properties thanks to TURBO ROOF TOP segment
- lightly cutting segment specification
- ideal for conduit drills
- also for freehand drilling

MATERIAL

concrete	✓✓
reinforced concrete	✓✓
sand-lime brick	✓✓
brickwork/bricks	✓✓
granite	✓
hard stone	✓

ITEM NUMBER	DESCRIPTION	Ø (MM)	ADAPTOR (MM)	NUMBERS OF SEGMENTS	SEGMENT THICKNESS(MM)	LIST PRICE RRP (WITHOUT VAT IN EUR)
340343	DBK-S	138	1 1/4" UNC	11	3,5	
340344	DBK-S	152	1 1/4" UNC	12	4,0	
340345	DBK-S	186	1 1/4" UNC	14	4,0	
340346	DBK-S	226	1 1/4" UNC	15	4,0	

MASTER DBK 3-HOLES



ADVANTAGES

- Premium wet core drill
- Crown segment height: 10 mm; 3-hole fixture
- working length 300 mm
- optimum drilling properties thanks to TURBO top segment
- ideal for conduit drills
- also for freehand drilling

MATERIAL

concrete	✓✓
reinforced concrete	✓✓
sand-lime brick	✓✓
brickwork/bricks	✓✓
granite	✓
hard stone	✓

ITEM NUMBER	DESCRIPTION	Ø (MM)	ADAPTOR (MM)	NUMBERS OF SEGMENTS	SEGMENT THICKNESS(MM)	LIST PRICE RRP (WITHOUT VAT IN EUR)
340325	DBK 3-holes	108	3-holes	8	3,5	
340326	DBK 3-holes	112	3-holes	9	3,5	
340327	DBK 3-holes	122	3-holes	10	3,5	
340328	DBK 3-holes	127	3-holes	11	3,5	
340329	DBK 3-holes	138	3-holes	11	3,5	
340330	DBK 3-holes	152	3-holes	12	4,0	
340331	DBK 3-holes	162	3-holes	12	4,0	
340332	DBK 3-holes	165	3-holes	12	4,6	
340333	DBK 3-holes	172	3-holes	12	4,6	
340334	DBK 3-holes	182	3-holes	13	4,6	
340335	DBK 3-holes	186	3-holes	13	4,6	
340336	DBK 3-holes	195	3-holes	13	4,6	
340337	DBK 3-holes	200	3-holes	14	4,6	
340338	DBK 3-holes	212	3-holes	14	4,6	
340339	DBK 3-holes	226	3-holes	15	4,6	
340340	DBK 3-holes	232	3-holes	15	4,6	
340341	DBK 3-holes	247	3-holes	16	4,0	
340342	DBK 3-holes	257	3-holes	16	4,6	

MASTER

DBD



ADVANTAGES

- Premium core drill with spiral body
- Crown segment height: 10 mm
- working length 300 mm
- special segment alloy for dry drilling
- low-vibration & clean work
- universal and fast

MATERIAL

concrete	✓✓
brickwork	✓✓
sand-lime brick	✓✓

ITEM NUMBER	DESCRIPTION	Ø (MM)	ADAPTOR (MM)	NUMBERS OF SEGMENTS	SEGMENT THICKNESS(MM)	LIST PRICE RRP (WITHOUT VAT IN EUR)
340477	DBD	52	1 1/4" UNC	5	3,5	
340478	DBD	57	1 1/4" UNC	5	3,5	
340479	DBD	62	1 1/4" UNC	5	3,5	
340480	DBD	67	1 1/4" UNC	5	3,5	
340481	DBD	72	1 1/4" UNC	6	3,5	
340482	DBD	82	1 1/4" UNC	6	3,5	
340483	DBD	102	1 1/4" UNC	7	3,5	
340484	DBD	112	1 1/4" UNC	7	3,5	
340485	DBD	122	1 1/4" UNC	8	3,5	
340486	DBD	127	1 1/4" UNC	8	3,5	
340487	DBD	132	1 1/4" UNC	8	3,5	
340488	DBD	142	1 1/4" UNC	8	3,5	
340489	DBD	152	1 1/4" UNC	8	3,5	
340490	DBD	162	1 1/4" UNC	9	3,8	
340491	DBD	182	1 1/4" UNC	9	3,8	
340492	DBD	202	1 1/4" UNC	10	3,8	



CORING/DRILLING

CONCRETE

MASTER DBR



ADVANTAGES

- Premium wet core drill
- Crown segment height: 10 mm
- working length 300 mm
- ideal for setting heavy-load anchors
- R 1/2" connection
- also for freehand drilling

MATERIAL

concrete	✓✓
reinforced concrete	✓✓
sand-lime brick	✓✓
brickwork/bricks	✓✓
granite	✓
hard stone	✓

ITEM NUMBER	DESCRIPTION	Ø (MM)	ADAPTOR (MM)	NUMBERS OF SEGMENTS	SEGMENT THICKNESS(MM)	LIST PRICE RRP (WITHOUT VAT IN EUR)
340086	DBR	16	R1/2"	1	2,5	
340087	DBR	18	R1/2"	1	2,5	
340088	DBR	20	R1/2"	1	2,5	
340089	DBR	22	R1/2"	1	2,5	
340090	DBR	24	R1/2"	1	2,5	
340091	DBR	25	R1/2"	1	2,5	
340092	DBR	26	R1/2"	1	2,5	
340093	DBR	28	R1/2"	1	2,5	
340094	DBR	30	R1/2"	1	2,5	
340095	DBR	32	R1/2"	1	2,5	
340096	DBR	35	R1/2"	1	2,5	

Other working lengths and diameters available on request

MASTER DBH



ADVANTAGES

- Premium wet core drill with thin segments
- Crown segment height: 10 mm
- working length 300 mm
- R 1/2" connection
- ideal for freehand drilling

MATERIAL

concrete	✓✓
reinforced concrete	✓✓
sand-lime brick	✓✓
brickwork/bricks	✓✓
granite	✓
hard stone	✓

ITEM NUMBER	DESCRIPTION	Ø (MM)	ADAPTOR (MM)	NUMBERS OF SEGMENTS	SEGMENT THICKNESS(MM)	LIST PRICE RRP (WITHOUT VAT IN EUR)
340350	DBH	41	R 1/2"	4	2,6	
340351	DBH	46	R 1/2"	4	2,6	
340352	DBH	51	R 1/2"	5	2,6	
340353	DBH	56	R 1/2"	5	2,6	
340354	DBH	61	R 1/2"	6	2,6	
340355	DBH	66	R 1/2"	6	2,6	
340356	DBH	71	R 1/2"	7	2,6	
340357	DBH	76	R 1/2"	8	2,6	
340400	DBH	81*	R 1/2"	8	2,6	
340358	DBH	81	R 1/2"	8	2,6	
340359	DBH	91	R 1/2"	9	2,6	
340360	DBH	101	R 1/2"	10	2,6	
340361	DBH	111	R 1/2"	11	2,6	
340362	DBH	121	R 1/2"	11	2,6	
340363	DBH	125	R 1/2"	11	2,6	
340364	DBH	130	R 1/2"	11	2,6	
340365	DBH	140	R 1/2"	11	2,6	
340366	DBH	150	R 1/2"	11	2,6	
340367	DBH	160	R 1/2"	12	2,6	
340368	DBH	170	R 1/2"	12	2,6	
340369	DBH	180	R 1/2"	12	2,6	
340370	DBH	200	R 1/2"	12	2,6	

*effective length 70 mm available on request

MASTER DBS-L

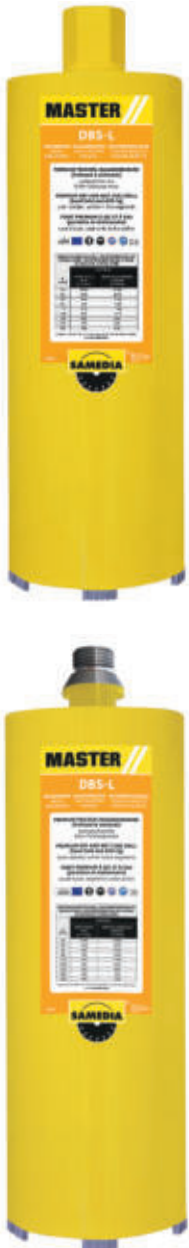

ADVANTAGES

- Premium dry and wet core bit
- Crown segment height: 8 mm
- working length 300 mm
- laser welded active Turbo segments
- universal & fast
- for free-hand and stationary use

MATERIAL

lightweight concrete	✓✓
sand-lime brick	✓✓
brickwork/bricks	✓✓
fire brick/refractory brick	✓

ITEM NUMBER	DESCRIPTION	Ø (MM)	ADAPTOR (MM)	NUMBERS OF SEGMENTS	SEGMENT THICKNESS(MM)	LIST PRICE RRP (WITHOUT VAT IN EUR)
340187	DBS-L	32	1 1/4" UNC	3	3,5	
340188	DBS-L	42	1 1/4" UNC	3	3,5	
340189	DBS-L	52	1 1/4" UNC	3	3,5	
340190	DBS-L	62	1 1/4" UNC	3	3,5	
340181	DBS-L	68	1 1/4" UNC	3	3,5	
340191	DBS-L	72	1 1/4" UNC	4	3,5	
340192	DBS-L	82	1 1/4" UNC	4	3,5	
340193	DBS-L	92	1 1/4" UNC	4	3,5	
340194	DBS-L	102	1 1/4" UNC	5	3,5	
340195	DBS-L	112	1 1/4" UNC	5	3,5	
340182	DBS-L	122	1 1/4" UNC	6	3,5	
340196	DBS-L	127	1 1/4" UNC	6	4,3	
340179	DBS-L	132	1 1/4" UNC	6	4,3	
340415	DBS-L	142	1 1/4" UNC	6	4,3	
340197	DBS-L	152	1 1/4" UNC	6	4,3	
340198	DBS-L	162	1 1/4" UNC	7	4,3	
340416	DBS-L	172	1 1/4" UNC	7	4,3	
340199	DBS-L	182	1 1/4" UNC	7	4,3	
340200	DBS-L	202	1 1/4" UNC	8	4,3	
340210	DBS-L	225	1 1/4" UNC	12	4,3	
340457	DBS-L	232	1 1/4" UNC	12	4,3	
340371	DBS-L	250	1 1/4" UNC	12	4,3	
340442	DBS-L	257	1 1/4" UNC	12	4,3	

ITEM NUMBER	DESCRIPTION	Ø (MM)	ADAPTOR (MM)	NUMBERS OF SEGMENTS	SEGMENT THICKNESS(MM)	LIST PRICE RRP (WITHOUT VAT IN EUR)
340272	DBS-L	32	R1/2"	3	3,8	
340273	DBS-L	42	R1/2"	3	3,8	
340274	DBS-L	52	R1/2"	3	3,8	
340275	DBS-L	62	R1/2"	3	3,8	
340276	DBS-L	68	R1/2"	3	3,8	
340277	DBS-L	72	R1/2"	4	3,8	
340278	DBS-L	82	R1/2"	4	3,8	
340279	DBS-L	92	R1/2"	4	3,8	
340280	DBS-L	102	R1/2"	5	3,8	
340281	DBS-L	112	R1/2"	5	3,8	
340282	DBS-L	122	R1/2"	6	3,5	
340283	DBS-L	127	R1/2"	6	4,3	
340284	DBS-L	132	R1/2"	6	4,3	
340285	DBS-L	152	R1/2"	6	4,3	
340286	DBS-L	162	R1/2"	7	4,3	
340287	DBS-L	182	R1/2"	7	4,3	
340288	DBS-L	202	R1/2"	8	4,3	

Other working lengths and diameters available on request



CORING/DRILLING

CONCRETE

UNIVERSAL



HIGHEND-CORE BITS

SEGMENT HEIGHT:
10 MM

SPECIAL FOR
**EXTREME DENSE
SAND-LIME BRICK**

ESPECIALLY
FOR DRILLS WITH
DUST EXTRACTION

MUST BE USED
WITHOUT PERCUSSION



More information



ITEM NUMBER	DESCRIPTION	Ø (MM)	ADAPTOR (MM)	NUMBERS OF SEGMENTS	SEGMENT THICKNESS(MM)	LIST PRICE RRP (WITHOUT VAT IN EUR)
390367	DAX	68	M16	4	3,5	
390368	DAX	82	M16	5	3,5	

MATERIAL

extreme dense sand-lime brick brick	✓✓
sand-lime brick	✓✓
brickwork/bricks	✓✓
lightweight concrete	✓



MASTER // DAM



ADVANTAGES

- Premium socket core bits
- segment height: 8 mm
- suitable with dust extraction machine
- must be used without percussion!
- not suitable for reinforced concrete!

MATERIAL

(highly-dense) sand-lime brick	✓✓
sand-lime brick	✓✓
brickwork/bricks	✓✓
lightweight concrete	✓

ITEM NUMBER	DESCRIPTION	Ø (MM)	ADAPTOR (MM)	NUMBERS OF SEGMENTS	SEGMENT THICKNESS(MM)	LIST PRICE RRP (WITHOUT VAT IN EUR)
340123	DAM	68	M16	4	3,5	
340124	DAM	82	M16	6	3,5	

MASTER // DSM



ADVANTAGES

- Premium socket core bits
- segment height: 8 mm
- (highly-dense) sand-lime brick
- must be used without percussion!

MATERIAL

(highly-dense) sand-lime brick	✓✓
sand-lime brick	✓✓
brickwork/bricks	✓✓
lightweight concrete	✓

ITEM NUMBER	DESCRIPTION	Ø (MM)	ADAPTOR (MM)	NUMBERS OF SEGMENTS	SEGMENT THICKNESS(MM)	LIST PRICE RRP (WITHOUT VAT IN EUR)
390011	DSM	68	M16	4	3,5	
390012	DSM	82	M16	6	3,5	

TECHNIC // DST



ADVANTAGES

- Professional socket core bits
- segment height: 8 mm
- must be used without percussion!

MATERIAL

sand-lime brick	✓✓
brickwork/bricks	✓✓

ITEM NUMBER	DESCRIPTION	Ø (MM)	ADAPTOR (MM)	NUMBERS OF SEGMENTS	SEGMENT THICKNESS(MM)	LIST PRICE RRP (WITHOUT VAT IN EUR)
390013	DST	68	M16	4	3,5	
390014	DST	82	M16	6	3,5	

SOLID

DSE



ADVANTAGES

- Standard socket core bits
- segment height: 8 mm
- suitable with dust extraction machine
- must be used without percussion!
- not suitable for reinforced concrete!

MATERIAL

brickwork/bricks	✓✓
lightweight concrete	✓
sand-lime brick	✓

ITEM NUMBER	DESCRIPTION	Ø (MM)	ADAPTOR (MM)	NUMBERS OF SEGMENTS	SEGMENT THICKNESS(MM)	LIST PRICE RRP (WITHOUT VAT IN EUR)
390343	DSE	82	M16	4	3,8	

Accessories

DSZ/DAZ



DSZ 200 Adapter Set SDS Plus on socket sinker M16

- 1x Adapter SDS
- 1x centering drill
- 1x extracting key

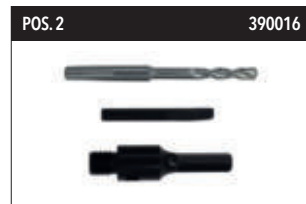

DSZ 100 Hex Adapter Set on socket sinker M 16

- 1x Hex Adapter
- 1x centering drill
- 1x extracting key



DSZ 150 centering drill

for DSZ 200 (390017/Pos. 1) and DSZ 100 (390016/Pos. 2)
2 pieces



Centering bit 140 mm

for DAZ 300 (390094/Pos. 5) and DAZ 100 (390091/Pos. 6)



DAZ 300 Adapter M18/M16 with centering bit

For using the diamond socket core bits DSM, DST and DAM on drilling machine with M18-thread (or additional adapter 390093 or 390092).



DAZ 100 Dust Exhausting

Unit for core bits DAX/DAM/ DSE. Can be used direct on coring machines with M18 thread (or in combination with adapters 390092 and 390093).



DAZ 200 Adapter SDS Plus

for DAZ 100 (390091/Pos. 6) M18 male x 2,5



DAZ 150 Hexagon Adapter

for DAZ 100 (390091/Pos. 6) M18 x 2,5

POS	ITEM NUMBER	DESCRIPTION	ADAPTOR (MM)	LIST PRICE RRP (WITHOUT VAT IN EUR)
1	390017	DSZ 200 Adapter Set SDS Plus	M16	
2	390016	DSZ 100 Hex Adapter Set	M16	
3	390108	DSZ 150 centering drill, 2 pieces	-	
4	390225	Centering bit 140 mm	-	
5	390094	DAZ 300 Adapter M18/M16 with centering bit	M18/M16	
6	390091	DAZ 100 Dust Exhausting	M18	
7	390093	DAZ 200 Adapter SDS Plus	M18	
8	390092	DAZ 150 Hexagon Adapter	M18	

SHOXX®

POWER INSIDE

DBV 



**HIGH-END-
DIAMOND CORE BITS**

SEGMENT HEIGHT:
15 MM

DRY DRILLING OF
**PORCELAIN STONE-
WARE (UP TO 2 CM
THICK)**

CAN BE USED **WITHOUT
CENTRING DEVICE**

FOR ALL CONVENTIONAL
ANGLE GRINDERS WITH
M14 THREAD



More information



ITEM NUMBER	DESCRIPTION	Ø (MM)	ADAPTOR (MM)	LIST PRICE RRP (WITHOUT VAT IN EUR)
340055	DBV	6	M14	
340056	DBV	8	M14	
340025	DBV	10	M14	
340026	DBV	12	M14	
340027	DBV	14	M14	
340451	DBV	16	M14	
340028	DBV	20	M14	
340030	DBV	26	M14	
340031	DBV	32	M14	
340183	DBV	35	M14	
340032	DBV	38	M14	
340431	DBV	40	M14	
340033	DBV	45	M14	
340184	DBV	50	M14	
340185	DBV	55	M14	
340034	DBV	58	M14	
340186	DBV	60	M14	
340035	DBV	65	M14	
340080	DBV	68	M14	
340036	DBV	70	M14	
340037	DBV	80	M14	
340038	DBV	110	M14	
340432	DBV	120	M14	
340450	DBV	125	M14	

MATERIAL

porcelain stoneware	✓✓
ceramics/tiles	✓✓
artificial stone/marble	✓✓
glass/fibre-glass	✓✓
porcelain	✓✓
roof tiles	✓✓



CORING/DRILLING

UNIVERSAL

TILES

SHOXX[®]

POWER INSIDE

DBV-SETS

POS. 1 380685



POS. 2 380763



ADVANTAGES

- vacuum brazed diamond core bits with M14 adaptor
- Perfect dry drill bit for hard tiles, porcelain stoneware (also 2cm strong) and granite tiles
- **Pos. 1:** recommendation for sanitary fitters for setting dowels
- **Pos. 2:** optimal for tilers for larger boreholes

MATERIAL

porcelain stoneware	✓✓
ceramics/tiles	✓✓
artificial stone/marble	✓✓
glass/fibre-glass	✓✓
porcelain	✓✓
roof tiles	✓✓

POS.	ITEM NUMBER	DESCRIPTION	LIST PRICE RRP (WITHOUT VAT IN EUR)
1	380685	Drill-Set 4-pcs., include 1 item each DBV Ø 6/8/10/14 mm	
2	380763	Drill-Set 8-pcs., include 1 item each DBV Ø 20/25/32/38/45/58/65/70 mm	

TECHNIC

DBV-E



ADVANTAGES

- Professional diamond core drill M14 for dry drilling
- segment height: 15 mm
- vacuum brazed

MATERIAL

porcelain stoneware	✓✓
ceramics/tiles	✓✓

ITEM NUMBER	DESCRIPTION	Ø (MM)	ADAPTOR (MM)	LIST PRICE RRP (WITHOUT VAT IN EUR)
340215	DBV-E	6	M14	
340216	DBV-E	8	M14	
340217	DBV-E	10	M14	
340218	DBV-E	12	M14	
340219	DBV-E	14	M14	
340220	DBV-E	16	M14	
340221	DBV-E	20	M14	
340222	DBV-E	25	M14	
340223	DBV-E	32	M14	
340224	DBV-E	35	M14	
340225	DBV-E	38	M14	
340436	DBV-E	40	M14	
340226	DBV-E	45	M14	
340227	DBV-E	50	M14	
340228	DBV-E	55	M14	
340229	DBV-E	58	M14	
340230	DBV-E	60	M14	
340231	DBV-E	65	M14	
340232	DBV-E	68	M14	
340233	DBV-E	70	M14	
340234	DBV-E	75	M14	
340235	DBV-E	80	M14	
340236	DBV-E	110	M14	

TECHNIC

DBV-E SETS



ADVANTAGES

- vacuum-brazed professional diamond drill bit sets with M14 thread for use on all conventional angle grinders
- for dry drilling without centering device
- ideal for tiler and sanitary fitters

MATERIAL

porcelain stoneware	✓✓
ceramics/tiles	✓✓

POS.	ITEM NUMBER	DESCRIPTION	LIST PRICE RRP (WITHOUT VAT IN EUR)
	380948	4-piece drill bit set include 1 item each DBV-E Ø 6/8/10/14 mm	
	380949	5-piece drill bit set include 1 item each DBV-E Ø 20/32/38/45/68 mm	
	380950	8-piece drill bit set include 1 item each DBV-E Ø 20/25/32/40/45/50/58/68 mm	

MASTER

TILER-SETS



SET COMPONENTS

- | | |
|--|--|
| <p>POS. 1 (380813)</p> <ul style="list-style-type: none"> • 4x DBV (Ø20/38/45/65 mm) • 1x diamond blade KTM (Ø125x22,23) • 1x diamond grinding cup Z-A5 (Ø125x22,23) | <p>POS. 2 (380814)</p> <ul style="list-style-type: none"> • 5x DBV (Ø20/32/38/45/68mm) • 3x diamond hand grinding pads HSP (granulation 120/200/400) • 1x diamond blade KTM (Ø125x22,23) • 1x Diamond grinding cup wheel UBM (Ø125x22,23) |
|--|--|

POS.	ITEM NUMBER	DESCRIPTION	LIST PRICE RRP (WITHOUT VAT IN EUR)
1	380813	Profi-Set tiler 1, 6-pcs.	
2	380814	Profi-Set tiler 2, 10-pcs.	

Save cost!



CORING/DRILLING

TILES

SHOXX[®]

POWER INSIDE

DBT/DBZ



ADVANTAGES

- Premium diamond core drill 6-kant
- segment height: 10 mm
- vacuum brazed dry core bit for dry drilling porcelain stoneware (also 2 cm thick)
- for all conventional drills and cordless drills (min. 1,500 rpm)

MATERIAL

porcelain stoneware	✓✓
ceramics/tiles	✓✓
artificial stone/marble	✓✓
glass/fibre-glass	✓✓
porcelain	✓✓
roof tiles	✓✓

ITEM NUMBER	DESCRIPTION	Ø (MM)	ADAPTOR (MM)	LIST PRICE RRP (WITHOUT VAT IN EUR)
340439	DBT	5	hexagon	
340073	DBT	6	hexagon	
340074	DBT	8	hexagon	
340075	DBT	10	hexagon	
340076	DBT	12	hexagon	
340077	DBT	14	hexagon	
390053	DBZ centring device 6-40 mm for DBT dry core drills			
390049	DBZ 200 adapter Hex/M14			

SHOXX[®]

POWER INSIDE

DBT-SET

4 PIECES



ADVANTAGES

- Premium diamond core drill 6-kant
- segment height: 10 mm
- vacuum brazed dry core bit for drilling porcelain stoneware (also 2 cm thick)
- for all conventional and cordless drilling machines (min. 1,500 rpm)

MATERIAL

porcelain stoneware	✓✓
ceramics/tiles	✓✓
artificial stone/marble	✓✓
glass/fibre-glass	✓✓
porcelain	✓✓
roof tiles	✓✓

ITEM NUMBER	DESCRIPTION	LIST PRICE RRP (WITHOUT VAT IN EUR)
380106	DBT-Set Ø 6/8/10 mm, hexagon and DBZ centring device 6-40 mm	

TECHNIC



DBT-E 



ADVANTAGES

- Professional diamond core drill
- segment height: 15 mm
- vacuum brazed
- for dry drilling
- ideal for cordless drills

MATERIAL

- porcelain stoneware 
- ceramics/tiles 

ITEM NUMBER	DESCRIPTION	Ø (MM)	DRILLING (MM)	LIST PRICE RRP (WITHOUT VAT IN EUR)
340440	DBT-E	5	1/4" Bit-Adaptor	
340267	DBT-E	6	1/4" Bit-Adaptor	
340268	DBT-E	8	1/4" Bit-Adaptor	
340269	DBT-E	10	1/4" Bit-Adaptor	
340270	DBT-E	12	1/4" Bit-Adaptor	
340271	DBT-E	14	1/4" Bit-Adaptor	

MASTER

DZB 



5 PIECES



ADVANTAGES

- special carbide roof tile drill for rotary drilling
- ideal for cordless drills
- in a practical box with 5 pcs.

MATERIAL

- roof tiles 
- cement asbestos 
- slate 
- tiles 

ITEM NUMBER	DESCRIPTION	Ø (MM)	DRILLING DEPTH (MM)	ADAPTOR (MM)	LIST PRICE RRP (WITHOUT VAT IN EUR)
340417	DZB	4	40	Special drill shaft	
340418	DZB	5	50	Special drill shaft	
340419	DZB	6	60	Special drill shaft	



CORING/DRILLING

TILES



CUTTING

CTS 800 830 AMPHIBIA
DRY & WET USING ONE MACHINE!



CORING/DRILLING

BSS 350
CORING WITH SYSTEM



GRINDING

FGR 500
FLOOR GRINDING
FOR PROFESSIONALS



PROFESSIONAL MACHINES

FROM PAGE 101



www.samedia.com



RECOMMENDATION TABLE GRINDING CUP WHEELS FREEHAND

MATERIAL	CONCRETE			UNIVERSAL			G.	A.	SPECIAL						
	Z U5	STU	Z A5	UBX	UBM	STB	STG	Z AH5	Z F5	C E5	RAP	PKD	PCD	STF	ST5
page	89	90	90	91	91	91	92	92	92	93	93	93	94	94	94
cement-based tile adhesive	✓✓	✓	✓✓	✓✓	✓	✓		✓✓						✓	
cement-based Flex tile adhesive			✓✓		✓			✓✓						✓	
dispersion tile adhesive			✓✓					✓✓			✓✓	✓✓	✓✓		
synthetic resin tile adhesive			✓✓					✓✓			✓✓	✓✓	✓✓		
screed	✓	✓	✓✓	✓	✓	✓		✓✓			✓			✓	✓
screed abrasive			✓		✓			✓✓			✓			✓	
bitumen screed	✓✓														
concrete	✓✓	✓✓	✓	✓✓	✓✓	✓✓	✓		✓✓	✓				✓✓	✓
granite	✓✓	✓✓	✓	✓✓	✓✓	✓	✓✓		✓					✓	
adhesive residues	✓	✓		✓	✓						✓✓	✓✓	✓✓		
carpet residues	✓	✓		✓						✓	✓✓	✓✓	✓✓		
coatings										✓✓	✓✓	✓✓	✓✓		
paints/graffiti			✓							✓✓	✓✓	✓	✓		
fibre-glass wall paper										✓✓					
bitumen										✓					
epoxy resin	✓			✓✓						✓✓	✓	✓✓	✓✓		

SHOXX TECHNOLOGY

When using grinding cup wheels, the segments have permanent contact to the tool. Slight deviations during the segment production and the fitting of the grinding cup wheels already result in imbalance and local overheating. This significantly impairs the lifetime of a grinding machine. A permanent, high grinding performance is guaranteed due to our accurate welding and the high-precision production of the segments using the SHOXX method. For the required cooling, it is very important to work with a good dust extraction system.

GRINDING PROPERTIES & IMBALANCE

In the following diagram, the grinding properties of grinding cup wheels are displayed depending on their imbalance. The highest demands in industrial production characterise our high-end grinding cup wheels. We achieve an extremely perfect concentricity without having to re-balance the finished tool. This is the basis of many benefits when being used.

Grinding properties depending on imbalance

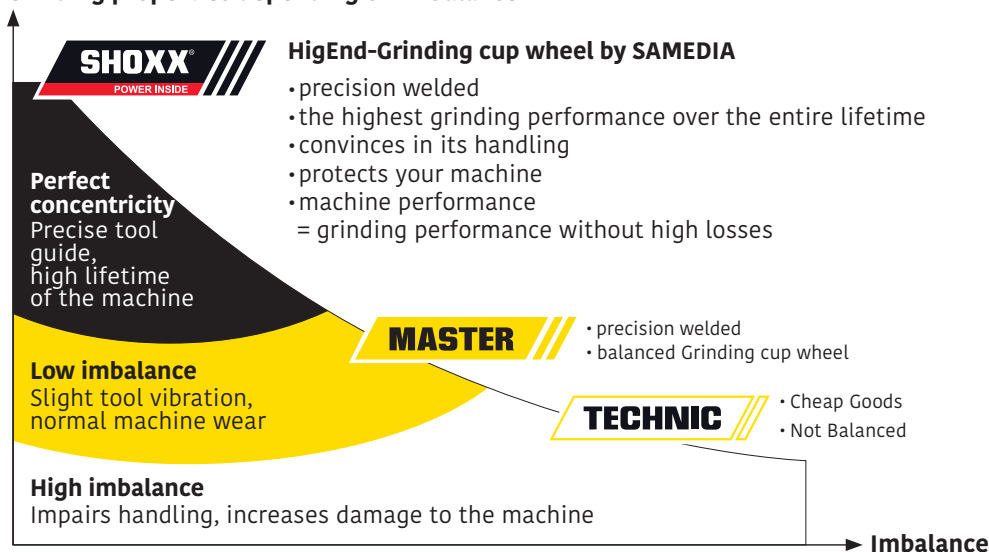

GRINDING MACHINES MANUFACTURER

Ø	BORE	EXECUTION	SAMEDIA	BOSCH	COLLOMIX	EIBENSTOCK	FESTOOL	FLEX	HILTI	MAKITA	METABO	MILWAUKEE
100	22,23	H = 22 mm										
115	22,23	H = 22 mm						✓✓*				
125	22,23	H = 22 mm	✓✓	✓✓	✓✓	✓✓		✓✓	✓✓	✓✓	✓✓	✓✓
125	M14	H = 22 mm										
130	25,00	H = 22 mm				✓✓						
150	19,00	H = 22 mm						✓✓				
150	22,23	H = 22 mm					✓✓					
180	22,23	H = 30 mm	✓✓		✓✓	✓✓						
180	22,23	H = 22 mm					✓✓					

*Adapter (39011) 22,23 mm, M14
Available on request.
H = height grinding cup wheel

The diamond cup wheels from Samedia are also compatible with many other manufacturers. You can find a selection here.

SHOXX® Z U5

POWER INSIDE

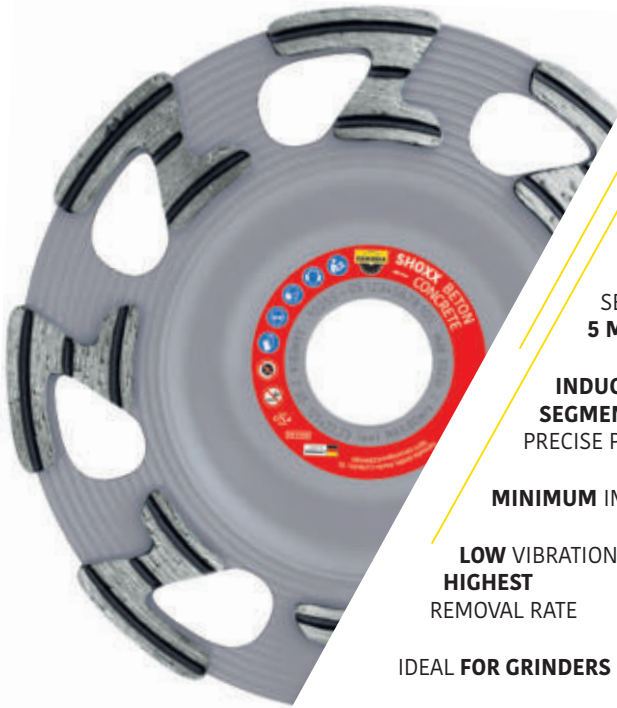

**HIGH-END-DIAMOND
GRINDING CUP WHEEL**

WITH **SHOXX**
FORGED SEGMENTS

SEGMENT HEIGHT:
5 MM

**INDUCTION WELDED
SEGMENTS UNDER
PRECISE POSITIONING**

MINIMUM IMBALANCE

**LOW VIBRATION,
HIGHEST
REMOVAL RATE**

IDEAL FOR GRINDERS



More information

MATERIAL

concrete	✓✓
granite	✓✓
cement-based tile adhesive	✓✓
bitumen screed	✓✓
screed	✓
adhesive residues	✓
carpet residues	✓
epoxy resin	✓

MADE IN GERMANY PRECISION WELDED EN 13236 compliant

ITEM NUMBER	DESCRIPTION	Ø (MM)	BORE (MM)	NUMBER OF SEGMENTS	SEGMENT THICKNESS (MM)	LIST PRICE RRP (WITHOUT VAT IN EUR)
350001	Z U5	100	22,23	8	22	
350019	Z U5	115	22,23	8	22	
350002	Z U5	125	22,23	8	22	
350020	Z U5	130	25	8	22	
350032	Z U5	150	19	10	22	
350103	Z U5	150	22,23	10	22	
350003	Z U5	180	22,23	12	30	
350010	Z U5	180 flat	22,23	12	22	



GRINDING

CONCRETE

MASTER STU



OS[®] EN 13236 compliant

MADE IN GERMANY

PRECISION WELDED

ADVANTAGES

- Premium grinding cup wheel
- segment height: 5,5 mm
- induction welded segments under precise positioning, minimum imbalance; low vibration
- especially easy to grind
- optimum dust extraction behaviour

MATERIAL

concrete	✓✓
granite	✓✓
cement-based tile adhesive	✓
screed	✓
adhesive residues	✓
carpet residues	✓

ITEM NUMBER	DESCRIPTION	Ø (MM)	BORE (MM)	NUMBER OF SEGMENTS	SEGMENT THICKNESS (MM)	LIST PRICE RRP (WITHOUT VAT IN EUR)
350073	STU	100	22,23	6	22	
350074	STU	115	22,23	6	22	
350075	STU	125	22,23	7	22	
350076	STU	150	19,00	9	22	
350077	STU	180	22,23	10	30	
350078	STU	180 flat	22,23	10	22	

SHOXX

POWER INSIDE

Z A5



OS[®] EN 13236 compliant

MADE IN GERMANY

PRECISION WELDED

ADVANTAGES

- High-End-diamond grinding cup wheel with SHOXX forged segments
- segment height: 5 mm
- precisionwelded segments, minimal imbalance, low-vibration
- highest removal rate
- ideal for grinders

MATERIAL

cement-based tile adhesive	✓✓	screed abrasive	✓
cement-based Flex tile adhesive	✓✓	concrete	✓
dispersion tile adhesive	✓✓	granite	✓
synthetic resin tile adhesive	✓✓	paints/graffiti	✓
screed	✓✓		

ITEM NUMBER	DESCRIPTION	Ø (MM)	BORE (MM)	NUMBER OF SEGMENTS	SEGMENT THICKNESS (MM)	LIST PRICE RRP (WITHOUT VAT IN EUR)
350004	Z A5	100	22,23	8	22	
350021	Z A5	115	22,23	8	22	
350005	Z A5	125	22,23	8	22	
350022	Z A5	130	25	8	22	
350033	Z A5	150	19	10	22	
350104	Z A5	150	22,23	10	30	
350006	Z A5	180	22,23	12	30	
350011	Z A5	180 flat	22,23	12	22	

MASTER // UBX



OS EN 13236 compliant

MADE IN GERMANY

PRECISION WELDED

ADVANTAGES

- Premium grinding cup wheel
- segment height: 5 mm
- precisionwelded segments, minimal imbalance, low-vibration
- high removal rate
- ideal for grinders from 1.500 W

MATERIAL

concrete	✓✓	screed	✓
granite	✓✓	adhesive residues	✓
cement-based tile adhesive	✓✓	carpet residues	✓
epoxy resin	✓✓		

ITEM NUMBER	DESCRIPTION	Ø (MM)	BORE (MM)	NUMBER OF SEGMENTS	SEGMENT THICKNESS (MM)	LIST PRICE RRP (WITHOUT VAT IN EUR)
350035	UBX	115	22,23	5	22	
350036	UBX	125	22,23	6	22	
350070	UBX	125	M14	6	30	
350037	UBX	150	19,00	7	22	
350086	UBX	150	22,23	7	22	
350038	UBX	180	22,23	8	30	
350039	UBX	180 flat	22,23	8	30	

MASTER // UBM



OS EN 13236 compliant

MADE IN GERMANY

PRECISION WELDED

ADVANTAGES

- Premium grinding cup wheel
- segment height: 5 mm
- induction welded segments under precise positioning, minimum imbalance; low vibration
- particularly suitable for low-power devices up to 1.200 Watt
- optimum dust extraction behaviour

MATERIAL

concrete	✓✓
granite	✓✓
cement-based tile adhesive	✓
cement-based Flex tile adhesive	✓
screed	✓
screed abrasive	✓
adhesive residues	✓

ITEM NUMBER	DESCRIPTION	Ø (MM)	BORE (MM)	NUMBER OF SEGMENTS	SEGMENT THICKNESS (MM)	LIST PRICE RRP (WITHOUT VAT IN EUR)
350049	UBM	115	22,23	5	22	
350050	UBM	125	22,23	5	22	
350051	UBM	150	19,00	7	22	
350089	UBM	150	22,23	7	22	
350052	UBM	180	22,23	8	30	

TECHNIC // STB



OS EN 13236 compliant

ADVANTAGES

- Professional diamond grinding cup wheel
- segment height: 6 mm
- brazed segments,
- double row

MATERIAL

concrete	✓✓
screed	✓
cement-based tile adhesive	✓
granite	✓

ITEM NUMBER	DESCRIPTION	Ø (MM)	BORE (MM)	NUMBER OF SEGMENTS	TOTAL HEIGHT THICKNESS (MM)	LIST PRICE RRP (WITHOUT VAT IN EUR)
350017	STB	115	22,23	18	22	
350018	STB	125	22,23	20	22	
350040	STB	180	22,23	24	30	



GRINDING

CONCRETE

UNIVERSAL

MASTER // STG



 EN 13236 compliant

ADVANTAGES

- Premium diamond grinding cup wheel with M14 thread
- segment height: 6 mm
- for clean surfaces
- diamond grit #40/50 (grade 1)

MATERIAL

granite	✓✓
concrete	✓

ITEM NUMBER	DESCRIPTION	Ø (MM)	ADAPTOR (MM)	DIAMOND COATING	TOTAL HEIGHT (MM)	LIST PRICE RRP (WITHOUT VAT IN EUR)
350151	STG	105	M14	Turbo	22	
350034	STG	125	M14	Turbo	22	

SHOXX®

POWER INSIDE

Z AH5



 EN 13236 compliant

MADE IN GERMANY 

PRECISION WELDED 

ADVANTAGES

- High-End-diamond grinding cup wheel with SHOXX forged segments
- segment height: 5 mm
- the specialist for screed
- precisionwelded segments, minimal imbalance, low-vibration
- highest removal rate
- maximum life time
- for use in abrasive materials
- ideal for grinders

MATERIAL

screed abrasive	✓✓
screed	✓✓
cement-based tile adhesive	✓✓
cement-based Flex tile adhesive	✓✓
dispersion tile adhesive	✓✓
synthetic resin tile adhesive	✓✓

ITEM NUMBER	DESCRIPTION	Ø (MM)	BORE (MM)	NUMBER OF SEGMENTS	TOTAL HEIGHT (MM)	LIST PRICE RRP (WITHOUT VAT IN EUR)
350098	Z AH5	115	22,23	8	22	
350099	Z AH5	125	22,23	8	22	
350087	Z AH5	130	25	8	22	
350097	Z AH5	150	19	10	22	
350102	Z AH5	150	22,23	10	22	
350100	Z AH5	180	22,23	12	30	
350101	Z AH5	180 flat	22,23	12	22	

SHOXX®

POWER INSIDE

Z F5

NEW!



 EN 13236 compliant

MADE IN GERMANY 

PRECISION WELDED 

ADVANTAGES

- High-End-diamond grinding cup wheel with SHOXX forged segments
- segment height: 5 mm
- precisionwelded segments, minimal imbalance, low-vibration
- very fine removal
- ideal for grinders

MATERIAL

concrete	✓✓
granite	✓

ITEM NUMBER	DESCRIPTION	Ø (MM)	BORE (MM)	NUMBER OF SEGMENTS	TOTAL HEIGHT (MM)	LIST PRICE RRP (WITHOUT VAT IN EUR)
350128	Z F5	125	22,23	8	5	
350134	Z F5	150	19	10	5	



C E5



 EN 13236 compliant

MADE IN GERMANY 

PRECISION WELDED 

ADVANTAGES

- High-End-diamond grinding cup wheel with SHOXX forged segments
- segment height: 5 mm
- precisionwelded segments, minimal imbalance, low-vibration
- very fine material removal
- ideal for grinders

MATERIAL

coatings	✓✓	concrete	✓
paints/graffiti	✓✓	carpet residues	✓
fibre-glass wall paper	✓✓	bitumen	✓
epoxy resin	✓✓		

ITEM NUMBER	DESCRIPTION	Ø (MM)	BORE (MM)	NUMBER OF SEGMENTS	TOTAL HEIGHT (MM)	LIST PRICE RRP (WITHOUT VAT IN EUR)
350007	C E5	100	22,23	8	22	
350129	C E5	115	22,23	8	22	
350008	C E5	125	22,23	8	22	
350085	C E5	130	25	8	22	
350047	C E5	150	19	10	22	
350046	C E5	150	22,23	10	22	
350009	C E5	180	22,23	12	30	
350012	C E5	180 flat	22,23	12	22	

MASTER RAP



EN 13236 compliant

MADE IN EUROPE 

ADVANTAGES

- Premium diamond grinding cup wheel
- segment height: 5 mm
- peeling and smoothing in one work step
- best for removal of coatings
- particularly suitable for floor renovation

MATERIAL

dispersion tile adhesive	✓✓	paints/graffiti	✓✓
synthetic resin tile adhesive	✓✓	screed	✓
adhesive residues	✓✓	screed abrasive	✓
carpet residues	✓✓	epoxy resin	✓
coatings	✓✓		

ITEM NUMBER	DESCRIPTION	Ø (MM)	BORE (MM)	NUMBER OF SEGMENTS	TOTAL HEIGHT (MM)	LIST PRICE RRP (WITHOUT VAT IN EUR)
350027	RAP	125	22,23	8	22	
350029	RAP	150	19	10	22	
350133	RAP	150	22,23	10	33	
350030	RAP	180	22,23	12	22,5	
350028	RAP	180 flat	22,23	12	22,5	

MASTER PKD



 EN 13236 compliant

ADVANTAGES

- Premium diamond grinding cup wheel
- with polycrystalline diamonds
- extremely high stock removal

MATERIAL

dispersion tile adhesive	✓✓	coatings	✓✓
synthetic resin tile adhesive	✓✓	epoxy resin	✓✓
adhesive residues	✓✓	paints/graffiti	✓
carpet residues	✓✓		

ITEM NUMBER	DESCRIPTION	Ø (MM)	BORE (MM)	NUMBER OF SEGMENTS	TOTAL HEIGHT (MM)	LIST PRICE RRP (WITHOUT VAT IN EUR)
350108	PKD	125	22,23	6	22	
350109	PKD	150	19,00	6	22	
350110	PKD	180	22,23	6	30	



GRINDING

GRANITE

ASPHALT

SPECIAL

MASTER PCD 



 EN 13236 compliant

ADVANTAGES

- Premium diamond grinding cup wheel
- with polycrystalline diamonds
- for near-edge milling

MATERIAL

dispersion tile adhesive	✓✓	coatings	✓✓
synthetic resin tile adhesive	✓✓	epoxy resin	✓✓
adhesive residues	✓✓	paints/graffiti	✓
carpet residues	✓✓		

ITEM NUMBER	DESCRIPTION	Ø (MM)	BORE (MM)	NUMBER OF SEGMENTS	TOTAL HEIGHT THICKNESS (MM)	LIST PRICE RRP (WITHOUT VAT IN EUR)
350015	PCD	125	22,23	12	22	
350016	PCD	180	22,23	6	34	

TECHNIC STF 

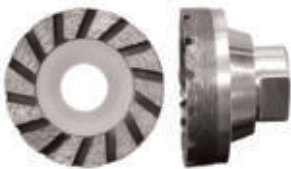

 EN 13236 compliant

ADVANTAGES

- Professional diamond grinding cup wheel
- segment height: 4 mm
- continuous turbo rim
- for grinding surfaces, edges and curves
- for hard to reach places
- versatile use

MATERIAL

concrete	✓✓
cement-based tile adhesive	✓
cement-based Flex tile adhesive	✓
screed	✓
screed abrasive	✓
granite	✓

ITEM NUMBER	DESCRIPTION	Ø (MM)	ADAPTOR (MM)	NUMBER OF SEGMENTS	TOTAL HEIGHT THICKNESS (MM)	LIST PRICE RRP (WITHOUT VAT IN EUR)
350079	STF	50	M14	1	30	

SOLID STS 



EN 13236 compliant

ADVANTAGES

- Standard diamond grinding cup wheel
- segment height: 4 mm
- direct sintered
- continuous turbo rim

MATERIAL

concrete	✓
screed	✓

ITEM NUMBER	DESCRIPTION	Ø (MM)	BORE (MM)	NUMBER OF SEGMENTS	TOTAL HEIGHT THICKNESS (MM)	LIST PRICE RRP (WITHOUT VAT IN EUR)
350061	STS	100	22,23	1	3,5	
350062	STS	110	22,23	1	3,5	
350063	STS	125	22,23	1	3,5	
350064	STS	180	22,23	1	3,5	

APPLICATION RANGE FLOOR GRINDERS

MATERIAL	SBM	SBX	PKR	PKD	PCD	SBA	RAP
cement-based tile adhesive	✓✓	✓✓	✓✓	✓✓	✓✓		
cement-based Flex tile adhesive	✓✓	✓✓	✓✓	✓✓	✓✓		
dispersion tile adhesive			✓✓	✓✓	✓✓		
synthetic resin tile adhesive			✓✓	✓✓	✓✓		
screed	✓	✓✓	✓	✓		✓✓	
screed abrasive		✓✓	✓	✓		✓✓	
bitumen screed			✓✓	✓✓	✓✓		
concrete	✓✓	✓	✓				✓✓
concrete abrasive	✓	✓✓	✓			✓✓	✓✓
granite	✓						
adhesive residues			✓✓	✓	✓✓		
carpet residues			✓✓	✓	✓✓		
coatings	✓	✓	✓✓	✓✓	✓✓		✓✓
paints	✓	✓	✓	✓	✓		✓✓
bitumen (only < 15° C)			✓✓	✓	✓✓		
epoxy resin			✓	✓✓	✓		

THE RIGHT CHOICE

of the diamond cup wheels depends from the surface and affects the desired grinding result. It will help to achieve the optimal expected result.

MASTER // SBM



EN 13236 compliant



ADVANTAGES

- Premium diamond grinding cup wheel for floor grinding machine FGR 500 for floor renovation
- segment height: 10 mm
- soft bond system for segments
- fine to medium material removal

MATERIAL

concrete	✓✓	concrete abrasiv	✓
cement-based tile adhesive	✓✓	screed	✓
cement-based Flex tile adhesive	✓✓	paints	✓
granite	✓	coatings	✓

ITEM NUMBER	DESCRIPTION	Ø (MM)	BORE (MM)	NUMBER OF SEGMENTS	TOTAL HEIGHT THICKNESS (MM)	LIST PRICE RRP (WITHOUT VAT IN EUR)
350111	SBM	300	22,23	8	22	

MASTER // SBX



EN 13236 compliant



ADVANTAGES

- Premium diamond grinding cup wheel for floor grinding machine FGR 500 for floor renovation
- segment height: 10 mm
- medium hard bond system for segments

MATERIAL

screed	✓✓	concrete abrasiv	✓✓
screed abrasive	✓✓	concrete	✓
cement-based tile adhesive	✓✓	paints	✓
cement-based Flex tile adhesive	✓✓	coatings	✓

ITEM NUMBER	DESCRIPTION	Ø (MM)	BORE (MM)	NUMBER OF SEGMENTS	SEGMENT THICKNESS (MM)	LIST PRICE RRP (WITHOUT VAT IN EUR)
350119	SBX	300	22,23	8	22	



GRINDING

SPECIAL

MASTER // SBA



EN 13236 compliant



ADVANTAGES

- Premium diamond grinding cup wheel for floor grinding machine FGR 500 for floor renovation
- segment height: 10 mm
- hard bond system for segments
- use on soft base surface

MATERIAL

screed abrasive	✓✓
screed	✓✓
concrete abrasiv	✓✓

ITEM NUMBER	DESCRIPTION	Ø (MM)	BORE (MM)	NUMBER OF SEGMENTS	SEGMENT THICKNESS (MM)	LIST PRICE RRP (WITHOUT VAT IN EUR)
350118	SBA	300	22,23	8	22	

MASTER // PKR



EN 13236 compliant



ADVANTAGES

- Premium diamond grinding cup wheel for floor grinding machine FGR 500 for floor renovation
- segment height: 4 mm
- with polycrystalline diamonds and additional RAP-segments (prevent immersion of the grinding cup wheel)
- medium material removal

MATERIAL

cement-based tile adhesive	✓✓	bitumen screed	✓✓
cement-based Flex tile adhesive	✓✓	bitumen (nur < 15° C)	✓✓
dispersion tile adhesive	✓✓	screed	✓
synthetic resin tile adhesive	✓✓	screed abrasive	✓
adhesive residues	✓✓	concrete abrasiv	✓
carpet residues	✓✓	concrete	✓
coatings	✓✓	epoxy resin	✓
paints	✓		

ITEM NUMBER	DESCRIPTION	Ø (MM)	BORE (MM)	NUMBER OF SEGMENTS	TOTAL HEIGHT THICKNESS (MM)	LIST PRICE RRP (WITHOUT VAT IN EUR)
350115	PKR	300	22,23	8	22	

MASTER // PKD



EN 13236 compliant



ADVANTAGES

- Premium diamond grinding cup wheel for floor grinding machine FGR 500 for floor renovation
- segment height: 5 mm
- with abrasive polycrystalline diamonds
- use on hard base surface
- heavy material removal

MATERIAL

cement-based tile adhesive	✓✓	adhesive residues	✓
cement-based Flex tile adhesive	✓✓	carpet residues	✓
dispersion tile adhesive	✓✓	paints	✓
synthetic resin tile adhesive	✓✓	bitumen (nur < 15° C)	✓
coatings	✓✓	screed	✓
bitumen screed	✓✓	screed abrasive	✓
epoxy resin	✓✓		

ITEM NUMBER	DESCRIPTION	Ø (MM)	BORE (MM)	NUMBER OF SEGMENTS	TOTAL HEIGHT THICKNESS (MM)	LIST PRICE RRP (WITHOUT VAT IN EUR)
350113	PKD	300	22,23	8	22	

MASTER PCD



EN 13236 compliant



ADVANTAGES

- Premium diamond grinding cup wheel for floor grinding machine FGR 500 for floor renovation
- segment height: 2,5 mm
- with fine polycrystalline diamonds
- medium to heavy material removal

MATERIAL

carpet residues	✓✓	coatings	✓✓
adhesive residues	✓✓	bitumen screed	✓✓
cement-based tile adhesive	✓✓	bitumen (nur < 15° C)	✓✓
cement-based Flex tile adhesive	✓✓	paints	✓
dispersion tile adhesive	✓✓	epoxy resin	✓
synthetic resin tile adhesive	✓✓		

ITEM NUMBER	DESCRIPTION	Ø (MM)	BORE (MM)	NUMBER OF SEGMENTS	TOTAL HEIGHT THICKNESS (MM)	LIST PRICE RRP (WITHOUT VAT IN EUR)
350114	PCD	300	22,23	8	22	

MASTER RAP



EN 13236 compliant



ADVANTAGES

- Premium diamond grinding cup wheel for floor grinding machine FGR 500 for floor renovation
- segment height: 5 mm
- very fine material removal
- ideal for roughening surfaces

MATERIAL

concrete	✓✓
concrete abrasiv	✓✓
coatings	✓✓
paints	✓✓

ITEM NUMBER	DESCRIPTION	Ø (MM)	BORE (MM)	NUMBER OF SEGMENTS	TOTAL HEIGHT THICKNESS (MM)	LIST PRICE RRP (WITHOUT VAT IN EUR)
350112	RAP	300	22,23	8	22	



MASTER // DFG



ADVANTAGES

- Premium finger milling bit
- for subsequent machining of edges and boreholes

MATERIAL

porcelain stoneware	✓✓
ceramics/Tiles	✓✓
natural stone	✓✓

ITEM NUMBER	DESCRIPTION	Ø (MM)	ADAPTOR (MM)	LIST PRICE RRP (WITHOUT VAT IN EUR)
340125	DFG	20	M14	
340126	DFG	10	M14	

MASTER // SSB



ADVANTAGES

- premium diamond grinding disc (curved)
- grit applied galvanically #100
- for edge breaking and chamfering for tiles
- approved up to 12250 rpm (= 80 m/s)

MATERIAL

porcelain stoneware	✓✓
ceramics/Tiles	✓✓
granite	✓✓
artificial stone/marble	✓✓

ITEM NUMBER	DESCRIPTION	Ø (MM)	BORE (MM)	GRANULATION (MM)	LIST PRICE RRP (WITHOUT VAT IN EUR)
350148	SSB	Ø125	22,23	# 100	

MASTER // TILER-SETS

POS. 1 380813



SET COMPONENTS

POS. 1 (380813)

- 4x DBV (Ø20/38/45/65 mm)
- 1x diamond blade KTM (Ø125x22,23)
- 1x diamond grinding cup wheel Z-A5 (Ø125x22,23)

POS. 2 (380814)

- 5x DBV (Ø20/32/38/45/68 mm)
- 3x diamond hand grinding pads HSP (granulation 120/200/400)
- 1x diamond blade KTM (Ø125x22,23)
- 1x Diamond grinding cup wheel UBM (Ø125x22,23)

POS. 2 380814



POS.	ITEM NUMBER	DESCRIPTION	LIST PRICE RRP (WITHOUT VAT IN EUR)
1	380813	Profi-Set tiler 1, 6-pcs.	
2	380814	Profi-Set tiler 2, 10-pcs.	

Save cost!

MASTER

SPM



ADVANTAGES

- SPM premium diamond grinding pad for angle grinders; performance and tool life prioritised
- for energy-saving use on speed-adjustable angle grinders
- Velcro fastening for quick tool changes (in combination with SPZ mounting plate)
- indispensable when regrinding sensitive edges on tiles
- recommended use at speeds up to 4500 rpm (< 25 m/s)
- for both wet and easy dry grinding

MATERIAL

porcelain stoneware	✓✓
ceramics/Tiles	✓✓
granite	✓✓
artificial stone/marble	✓✓

ITEM NUMBER	DESCRIPTION	Ø (MM)	COLOR CODE	GRANULATION (MM)	LIST PRICE RRP (WITHOUT VAT IN EUR)
350142	SPM grinding pad	Ø100	blue	# 50	
350143	SPM grinding pad	Ø100	yellow	# 100	
350144	SPM grinding pad	Ø100	orange	# 200	
350145	SPM grinding pad	Ø100	red	# 400	
350146	SPM grinding pad	Ø100	green	# 800	
350159	SPM grinding pad	Ø100	orange	# 1500	
350160	SPM grinding pad	Ø100	light pink	# 3000	
350161	SPM grinding pad	Ø100	black	# BUFF	
380982	SPM Premium-Starter-Set - Ø100 #50; #100; #200 + M14 plate				

TECHNIC

SPT



ADVANTAGES

- SPT professional diamond grinding pad for angle grinders; ECO version
- for energy-saving use on speed-adjustable angle grinders
- Velcro fastening for quick tool changes (in combination with SPZ mounting plate)
- indispensable when regrinding sensitive edges on tiles
- recommended use at speeds up to 4500 rpm (< 25 m/s)
- for both wet and easy dry grinding

MATERIAL

porcelain stoneware	✓✓
ceramics/Tiles	✓✓
granite	✓✓
artificial stone/marble	✓✓

ITEM NUMBER	DESCRIPTION	Ø (MM)	COLOR CODE	GRANULATION (MM)	LIST PRICE RRP (WITHOUT VAT IN EUR)
350136	SPT grinding pad	Ø100	neon green	# 50	
350137	SPT grinding pad	Ø100	red	# 100	
350138	SPT grinding pad	Ø100	neon yellow	# 200	
350139	SPT grinding pad	Ø100	blue	# 400	
350140	SPT grinding pad	Ø100	green	# 800	
380958	SPT Professional-Starter-Set - Ø100 #50; #100; #200 + M14 plate				



GRINDING

TILES

Accessories SPZ



ADVANTAGES

- Velcro mounting plate (Ø100/M14 rubber)
- flexible tool rest for easy handling
- for the use of diamond grinding pads on angle grinders (variable speed!)
- recommended use at speeds up to 4500 rpm (< 25 m/s)

ITEM NUMBER	DESCRIPTION	LIST PRICE RRP (WITHOUT VAT IN EUR)
350147	Velcro mounting plate, Ø100/M14 rubber	

MASTER SMT



EN 13236 compliant

ADVANTAGES

- Premium abrasive flap disc
- highly versatile abrasive flap disc for metal processing
- long service life with steep edges in corners

MATERIAL

Metall ✓✓

ITEM NUMBER	DESCRIPTION	Ø (MM)	GRANULATION	BORE (MM)	PACKAGING UNIT (PIECES)	LIST PRICE RRP (WITHOUT VAT IN EUR)
320011	SMT	115	40	22,23	10	
320012	SMT	115	60	22,23	10	
320013	SMT	115	80	22,23	10	
320014	SMT	125	40	22,23	10	
320015	SMT	125	60	22,23	10	
320016	SMT	125	80	22,23	10	

* with packing unit 10 (supplied in a cardboard box)

MANUAL GRINDING

MASTER HSP



ADVANTAGES

- Premium diamond hand grinding pads
- most suited for grinding and polishing edges and curved surfaces
- the ideal solution for professional tilers

MATERIAL

porcelain stoneware ✓✓
 ceramics/Tiles ✓✓
 granite ✓✓
 artificial stone/marble ✓✓
 concrete ✓✓

ITEM NUMBER	DESCRIPTION	SIZE (MM)	GRANULATION	COLOR CODE	LIST PRICE RRP (WITHOUT VAT IN EUR)
320026	HSP	90 x 55	# 60	green	
320019	HSP	90 x 55	# 120	black	
320020	HSP	90 x 55	# 200	red	
320021	HSP	90 x 55	# 400	yellow	



CUTTING

AGR 500 INCL. TOOLS



PROFESSIONAL-SET FOR TILERS AND PLUMBERS WITH **PREMIUM ANGLE GRINDER & TOOLS**



DETAILS

- Powerful 1000 W motor with electronic speed control, no-load speed: 2800-10500 rpm
- Marathon motor with up to 50% more torque and up to 20% more overload capacity for quicker removal of material and a longer life
- Protective hood adjustable without tools
- Mechanical safety coupling: minimises kick-back from blade blocking to the lowest level on the market - for maximum user protection and speedy continuation of work

TECHNICAL INFORMATION

Motor:	1,0 kW / 230 V
Speed:	2.800 - 10.500
Diameter:	125x22,23 mm
Weight:	2,1 kg

PROFESSIONAL SET

ITEM NUMBER	DESCRIPTION	LIST PRICE RRP (IN EURO WITHOUT VAT)
380876	Professional Set Tiler AGR 500 / 125mm	

SET COMPONENTS



1x AGR 500 angle grinder



1x DBV 20x45 M14 15x3
1x DBV 32x45 M14 15x3
1x DBV 38x45 M14 15x3



1x DBV 50x35 M14 15x3
1x DBV 65x35 M14 15x3



1x GTM 125x22,23



1x KTM 125x22,23



1x KVX 125x22,23



10x TKE 125x1,0x22,23
(VPE = 10 in a metal tin)



1x case

ECS 500

PROFESSIONAL ELECTRIC CUT-OFF SAW Ø350, SUITABLE FOR WET AND DRY CUTTING.

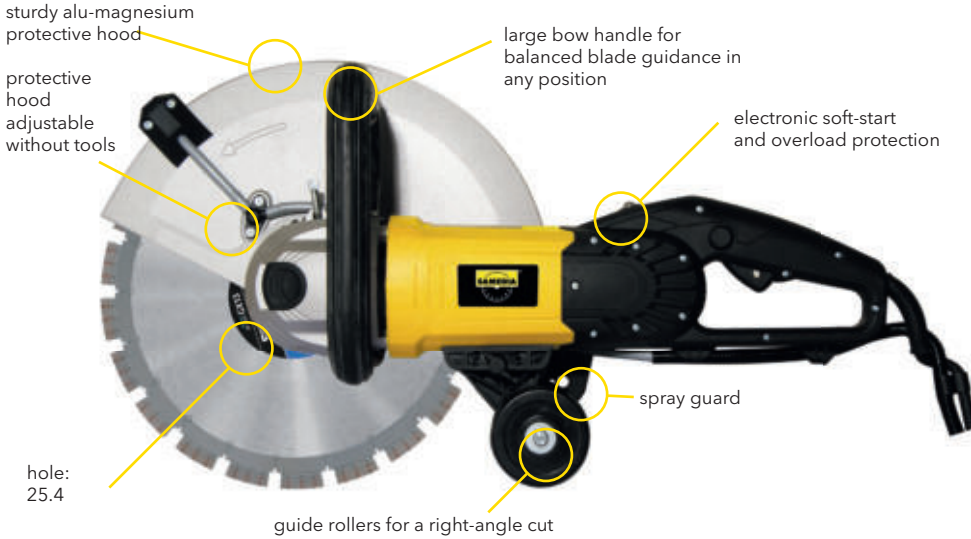

TECHNICAL INFORMATION

Motor:	2,8 kW / 230 V
Speed:	4500
Diameter:	350x25,4 mm
Cutting depth:	125 mm
Weight:	7,9 kg

ITEM NUMBER	DESCRIPTION	LIST PRICE RRP (IN EURO WITHOUT VAT)
370236	Electric cut-off saw Ø350	
370249	Shoe for wet and dust extraction	

ADVANTAGES



Water supply for wet cutting.

PROFESSIONAL SETS

ITEM NUMBER	DESCRIPTION	ECS 500	SHOXX GX13 SILENCIO	SHOE	LIST PRICE RRP (IN EURO WITHOUT VAT)
380893	ECS 500 Professional Set 1	✓	✓		
380904	ECS 500 Professional Set 2	✓	✓	✓	

AVAILABLE ACCESSORIES (not included)



Shoe

RECOMMENDED BLADES

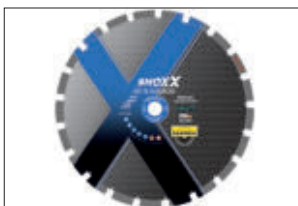

SHOXX GX13 Silencio*
see page 52

* SILENCIO = significant noise reduction of approx. 80% compared to the standard steel core.



CUTTING

CTS 800 830 AMPHIBIA®

INCL. UX13 AMPHIBIA®

MADE IN EUROPE



INNOVATIVE!

HIGH-END TABLE SAW FOR DRY AND WET CUTTING.

INCL. 1 SILENT, FULL CUT DIAMOND BLADE UX 13 AMPHIBIA®



closed dust circuit when dry cutting

high mobility of the pivoted head allows a greater cutting depth by turning the material over (wet-cutting only)

Integrated dust extraction channel
Simple conversion from dry to wet cutting (patent pending No. PCT/IE 2021/000002).

large transport wheels for easy manoeuvrability

*extraction device is not included (s. p. 150).

cutting table with ball-bearing mounted rollers



ADVANTAGES



Sophisticated filter system for a closed dust circuit.



Innovative change channel for simple conversion without using tools.



Switchable water pump for wet cutting.



Magnetic holder facilitates the dust bag to be changed within seconds.

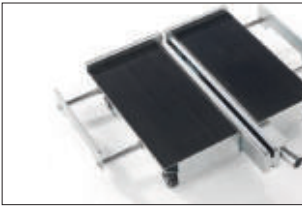

Special roller table with table extension integrated on both sides.



Effective extraction performance, including for full cuts.



Pull-out table extension for larger materials.



CTS 830 AMPHIBIA with high-torque special motor.

DETAILS CTS 800

- includes a SILENT diamond blade UX13 Amphibia® Ø350

DETAILS CTS 830

- includes a SILENT diamond blade UX13 AMPHIBIA® Ø450 mm
- high-torque special motor for guaranteeing optimum operating conditions of the cutting segments

TECHNICAL INFORMATION CTS 800

Motor:	2,2 kW / 230 V
Speed:	2800 min ⁻¹
Size of the cutting disc:	350 x 25,4 mm
Cutting length, dry cut:	440 mm / 460 mm / 470 mm / 480 mm
with material thickness:	9,5 cm / 5,0 cm / 4,0 cm / 3,0 cm
Cutting length, wet cut:	600 mm
Cutting depth, full cut:	95 mm
Max. cutting depth, wet cut:	110 mm
Weight:	109 kg (5 pcs.)
Dimensions LxWxH:	1110 x 600 x 1200 mm

ITEM NUMBER	DESCRIPTION	LIST PRICE RRP (IN EURO WITHOUT VAT)
370571	CTS 800 AMPHIBIA® INCL. 1x UX13 AMPHIBIA® Ø350	

TECHNICAL INFORMATION CTS 830

Motor:	2,2 kW / 230 V / 4P
Speed:	1400 min ⁻¹
Size of the cutting disc:	450 x 30,0 mm
Cutting length, dry cut:	380 mm / 430 mm / 440 mm / 455 mm
with material thickness:	13,5 cm / 5,0 cm / 4,0 cm / 3,0 cm
Cutting length, wet cut:	600 mm
Cutting depth, full cut:	135 mm
Max. cutting depth, wet cut:	145 mm
Weight:	120 kg (5 pcs.)
Dimensions LxWxH:	1110 x 600 x 1270 mm

ITEM NUMBER	DESCRIPTION	LIST PRICE RRP (IN EURO WITHOUT VAT)
370572	CTS 830 AMPHIBIA® INCL. 1x UX13 AMPHIBIA® Ø450	

RECOMMENDED BLADES



UX13 AMPHIBIA see page 48

AVAILABLE ACCESSORIES (not included)



VAC 520 see page 150



CTS 500 INCL. USM

MADE IN EUROPE



PREMIUM-TABLE SAW FOR UNIVERSAL USE WITH ROLLING TABLE.

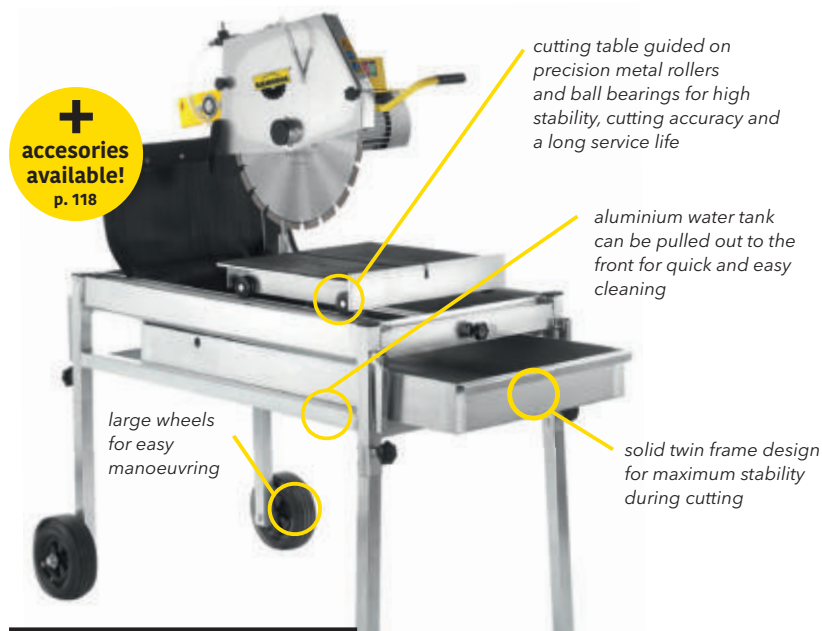

+
accessories
available!
p. 118

ADVANTAGES



High mobility of the pivoted head allows a greater cutting depth possible by turning the material over.



Diagonal cuts of 40 x 40 cm - simple and clean.



Undervoltage release protected against dust and splash water.



Water tank can be pulled out to the front. Practical for quick and easy cleaning.



Plug-in water pump for quick exchange without tools.

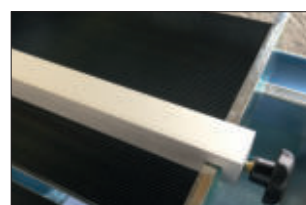

Incl. lengthwise end stop for precision cuts.

TECHNICAL INFORMATION

Motor:	2,2 kW / 230 V
Speed:	2800 min ⁻¹
Diameter:	350x25,4 mm
Cutting length*:	600 mm
Cutting depth:	110 mm
Weight:	92 kg
Dimensions LxWxH:	1110x600x1270 mm

*with plunge cut

ITEM NUMBER	DESCRIPTION	LIST PRICE RRP (IN EURO WITHOUT VAT)
370066	CTS 500 INCL. 1x USM Ø350	

VARIANTS

ITEM NUMBER	MOTOR	SPEED (MIN ⁻¹)	BLADE SIZE (MM)	CUTTING DEPTH (MM)	CUTTING LENGTH (MM)	LIST PRICE RRP (IN EURO WITHOUT VAT)
370148	2,6kW/230V	2800	Ø350x25,4	110	600	
370149	3,0kW/400V	2800	Ø350x25,4	110	600	
370150*	2,2kW/230V/4P	1400	Ø450x30,0	140	600	
370151	3,0kW/400V	2800	Ø450x25,4	150	600	

*speed-reduced

RECOMMENDED BLADES



MASTER USM see page 50

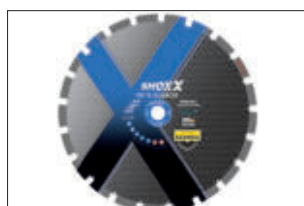

SHOXX GX13 SILENCIO s. page 52



SHOXX KX13 SILENCIO s. page 57

STM 350

INCL. USM

PROFESSIONAL TABLE SAW WITH ROLLING TABLE.

**DETAILS**

- Sturdy frame for precise cuts
- Rolling table on rollers with ball bearings
- Thermal switch protects the motor against overheating

TECHNICAL INFORMATION

Motor:	2,2 kW / 230 V
Speed:	2800 min ⁻¹
Diameter:	350x25,4 mm
Cutting length:	600 mm
Cutting depth:	105 mm
Weight:	71 kg
Dimensions LxWxH:	1300 x 803 x 1267 mm

ITEM NUMBER	DESCRIPTION	LIST PRICE RRP (IN EURO WITHOUT VAT)
380821	STM 350 INCL. 1x USM Ø350	

RECOMMENDED BLADES

MASTER USM see page 50

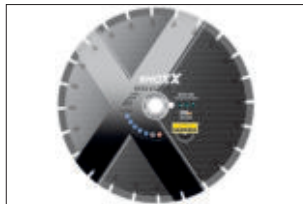

SHOXX KX13 SILENCIO s. page 57

**CUTTING**

CTS 650

INCL. DIA-SCHEIBE

MADE IN EUROPE



PREMIUM TABLE SAW FOR BUILDING MATERIALS, SAND-LIME BRICKS, CONCRETE PRODUCTS AND MASONRY BLOCKS.



+
acesories available!
 p. 118

DETAILS

- 4 parts: Cutting head, water tank, table frame, feet
- Cutting head with twin ball bearings
- Cutting head with gas pressure shock absorber
- Cutting table with ball-bearing mounted steel rollers
- Ideal cutting depth for 25 cm stones
- 420 mm cutting depth possible by turning the material over
- Motor with integrated motor brake and soft-start controller for maximum health and safety
- Direction of rotation can be reversed via a plug
- Direct drive of the diamond blade
- 4 closed crane hooks for safe relocation
- Fully galvanised
- Legs with wheels and large feet
- Plug-in water pump

TECHNICAL INFORMATION

Motor:	4,0 kW / 400 V
Speed:	1400 min ⁻¹
Diameter:	650x30 mm
Cutting length:	450 mm
Cutting depth:	250 mm
Weight:	125 kg
Dimensions LxWxH:	1300x710x1510 mm

ITEM NUMBER	DESCRIPTION	LIST PRICE RRP (IN EURO WITHOUT VAT)
370077	CTS 650 INCL. 1x Ø650x30	

ADVANTAGES



Solid twin frame design increases stability during cutting.



420 mm cutting depth possible by turning the material over.



Foldaway handles for ergonomic transport, and 4 support devices for pallet transport.



Water tank can be pulled out to the front. Practical for quick and easy cleaning.

RECOMMENDED BLADES



MASTER USM see page 50

FB 700

INCL. USM

MADE IN EUROPE



PREMIUM BLOCK CUTTING MACHINE FOR BUILDING CONSTRUCTION, ROAD CONSTRUCTION AND PAVERS.



CUTTING



+
accessories
available!
p. 118

TECHNICAL INFORMATION

Motor:	5,5 kW / 400 V
Speed:	2750 min ⁻¹
Diameter:	700x25,4 mm
Cutting length:	600 mm
Cutting depth:	290 mm
Weight:	350 kg
Dimensions LxWxH:	1470x900x1600 mm

ITEM NUMBER	DESCRIPTION	LIST PRICE RRP (IN EURO WITHOUT VAT)
370153	FB 700 INCL. 1x USM 700x25,4	

ADVANTAGES



A central crane hook. Motor with electric brake ensures quick stopping of the diamond blade.



4 additional metal handling hooks to transport the machine safely



Angle stop 0 -180 °.



Plug-in water pump for quick and safe replacement without tools.

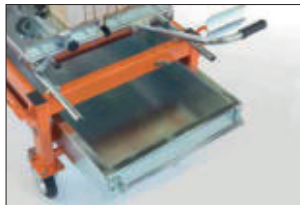

Extendable water tray.



Mobile cutting head with infinite adjustment allows precise cuts.

VARIANTS WITH BELT DRIVE

ITEM NUMBER	DESCRIPTION	MOTOR	SPEED (MIN ⁻¹)	BLADE SIZE (MM)	CUTTING DEPTH (MM)	CUTTING LENGTH (MM)	WEIGHT (KG)	LIST PRICE RRP (IN EURO WITHOUT VAT)
370152	FB 650 INCL. 1x USM Ø650	5,5 kW/400 V	2750	Ø650x25,4	270	600	350	

RECOMMENDED BLADES



MASTER USM see page 50

UTS 500

INCL. GX13 SILENCIO



TOP-GUIDED PREMIUM TABLE SAW FOR UNIVERSAL USE.

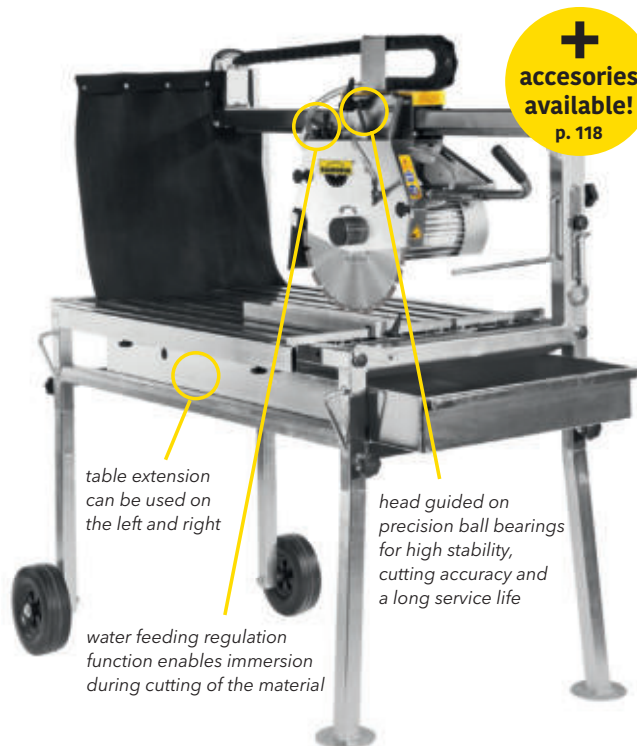

+
accessories
available!
p. 118

table extension
can be used on
the left and right

water feeding regulation
function enables immersion
during cutting of the material

head guided on
precision ball bearings
for high stability,
cutting accuracy and
a long service life

DETAILS

- 3-part machine consisting of: Machine base frame with cutting unit and plug-in feet; removable support table; removable aluminium water tray
- Torsion-resistant, solid double frame design for maximum stability
- Clean finished, retractable handles as well as crane hooks for transport

TECHNICAL INFORMATION

Motor:	2,2 kW / 230 V
Speed:	2800 min ⁻¹
Diameter:	350x25,4 mm
Cutting length:	800 mm
Cutting depth:	110 mm
Weight:	96 kg
Dimensions:	1150x600x1350 mm

ITEM NUMBER	DESCRIPTION	LIST PRICE RRP (IN EURO WITHOUT VAT)
370069	UTS 500 INCL. 1x GX13 Silencio Ø350	

ADVANTAGES



Aluminium water tank can be pulled out to the front. Practical for quick and easy cleaning.



Plug-in water pump for quick exchange without tools.



Elegant and practical cable carrier and hose routing.



Longitudinal stop made of solid aluminium suitable for the protected recessed scale.

VARIANTS

ITEM NUMBER	DESCRIPTION	MOTOR	SPEED (MIN ⁻¹)	BLADE SIZE (MM)	CUTTING DEPTH (MM)	CUTTING LENGTH (MM)	LIST PRICE RRP (IN EURO WITHOUT VAT)
370105	UTS 500 INCL. 1x GX13 Ø350 Silencio	2,6kW/230V	2800	Ø350x25,4	110	800	
370154	UTS 500 INCL. 1x GX13 Ø350 Silencio	3,0kW/400V	2800	Ø350x25,4	110	800	
370139*	UTS 500 INCL. 1x GX13 Ø450 Silencio	2,2kW/230V/4P	1400	Ø450x30,0	140	800	
370155	UTS 500 INCL. 1x GX13 Ø450 Silencio	3,0kW/400V	2800	Ø450x25,4	150	800	
370156	UTS 500 INCL. 1x GX13 Ø450 Silencio	4,0kW/400V	1400	Ø450x30,0	150	800	

*speed-reduced

RECOMMENDED BLADES



GX13 SILENCIO see page 52



SHOXX KSX see page 54



SHOXX KX13 SILENCIO s. page 57

UTS 520

INCL. **GX13 SILENCIO**

MADE IN EUROPE



TOP-GUIDED **PREMIUM TABLE SAW** FOR UNIVERSAL USE. IDEAL FOR PROCESSING LARGE-FORMAT CONCRETE AND NATURAL STONE PRODUCTS AS WELL AS FINE STONEWARE.

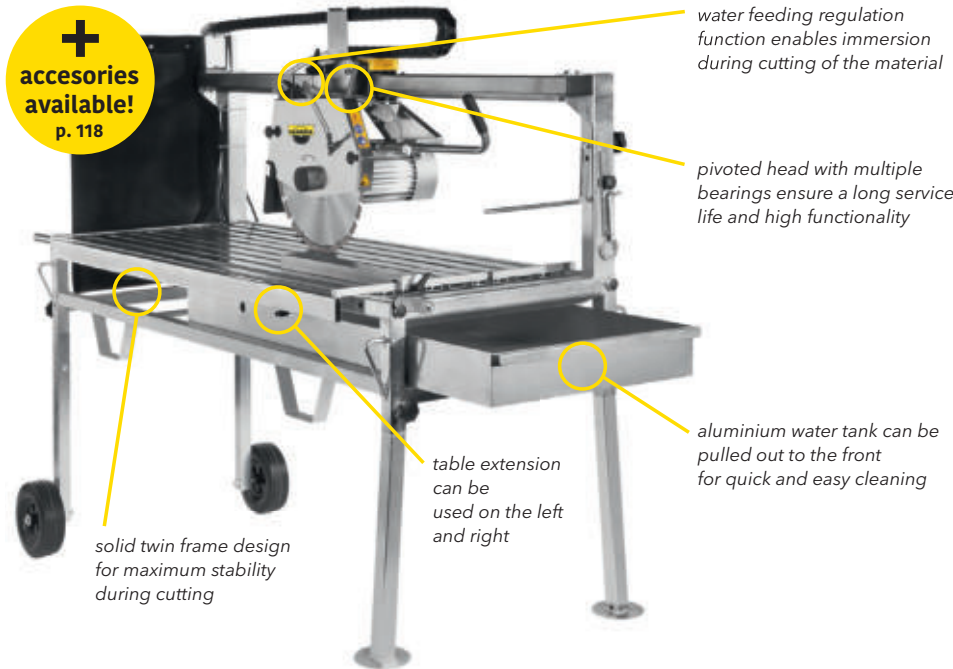

+
accessories available!
p. 118

water feeding regulation function enables immersion during cutting of the material

pivoted head with multiple bearings ensure a long service life and high functionality

solid twin frame design for maximum stability during cutting

table extension can be used on the left and right

aluminium water tank can be pulled out to the front for quick and easy cleaning

ADVANTAGES



Undervoltage release protected against dust and splash water.



Plug-in water pump for quick exchange without tools.



CUTTING

TECHNICAL INFORMATION

Motor:	2,2 kW / 230 V
Speed:	2800 min ⁻¹
Diameter:	350x25,4 mm
Cutting length:	1200 mm
Cutting depth:	110 mm
Weight:	110 kg
Dimensions:	1535x820x1380 mm

DETAILS

- 3-part machine consisting of: Machine base frame with cutting unit and plug-in feet; removable support table; removable aluminium water tray
- Torsion-resistant, solid double frame design for maximum stability
- Clean finished, retractable handles as well as crane hooks for transport

ITEM NUMBER	DESCRIPTION	LIST PRICE RRP (IN EURO WITHOUT VAT)
370067	UTS 520 INCL. 1x GX13 Silencio Ø350	

VARIANTS

ITEM NUMBER	DESCRIPTION	MOTOR	SPEED (MIN ⁻¹)	BLADE SIZE (MM)	CUTTING DEPTH (MM)	CUTTING LENGTH (MM)	LIST PRICE RRP (IN EURO WITHOUT VAT)
370075	UTS 520 INCL. 1x GX13 Silencio Ø350	2,6kW/230V	2800	Ø350x25,4	110	1200	
370157	UTS 520 INCL. 1x GX13 Silencio Ø350	3,0kW/400V	2800	Ø350x25,4	110	1200	
370074*	UTS 520 INCL. 1x GX13 Silencio Ø450	2,2kW/230V/4P	1400	Ø450x30,0	140	1200	
370158	UTS 520 INCL. 1x GX13 Silencio Ø450	3,0kW/400V	2800	Ø450x25,4	150	1200	
370159	UTS 520 INCL. 1x GX13 Silencio Ø450	4,0kW/400V	1400	Ø450x30,0	150	1200	

*speed-reduced

RECOMMENDED BLADES



GX13 SILENCIO see page 52



SHOXX KSX see page 54



SHOXX KX13 SILENCIO s. page 57

UTS 420

INCL. GX13 SILENCIO



TOP-GUIDED **PREMIUM TABLE SAW** FOR UNIVERSAL USE.
FOR BUILDING CONSTRUCTION, LANDSCAPING AND TILERS.

+
accessories
available!
p. 118



mobile cutting head on multiple bearings with rocker and integrated gas pressure shock absorber guarantees a precise cut

water feeding regulation function enables immersion during cutting of the material

ADVANTAGES



Aluminium water tank can be pulled out to the front. Practical for quick and easy cleaning.



Folding feet for easy transport.



Plug-in water pump for quick exchange without tools.



Longitudinal stop made of solid aluminium suitable for the protected recessed scale.



45 degree cuts from the right-hand side. The optional side table can easily be fixed on the left and right without tools.



Side table available as an accessory.

DETAILS

- 3-part machine consisting of: Machine base frame with cutting unit and fold-away feet; removable support table; removable aluminium water tray
- Solid bar handles and crane hooks for transport
- Quick clamping lever for simple set up

TECHNICAL INFORMATION

Motor:	2,2 kW / 230 V
Speed:	2800 min ⁻¹
Diameter:	350x25,4 mm
Cutting length:	1200 - 1275 mm
Cutting depth:	110 mm
Weight:	113 kg
Dimensions:	1700x680x1550 mm

ITEM NUMBER	DESCRIPTION	LIST PRICE RRP (IN EURO WITHOUT VAT)
370433	UTS 420 INCL. 1x GX13 Silencio Ø350	

RECOMMENDED BLADES



GX13 SILENCIO see page 52



SHOXX KSX see page 54



SHOXX KX13 SILENCIO s. page 57

UTS 630

INCL. **GX13 SILENCIO**

MADE IN EUROPE



VERSATILE **HIGHEND TABLE SAW** FOR TILERS AND NATURAL STONE PROCESSORS.



CUTTING

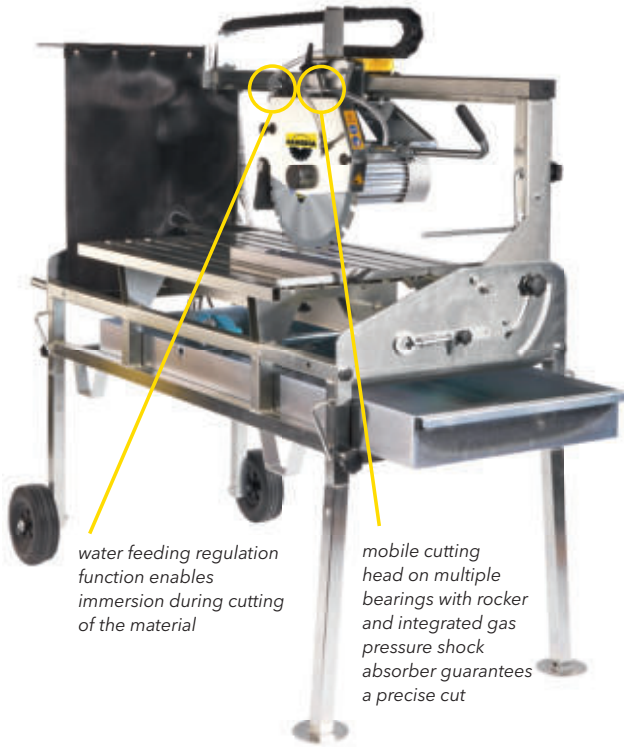

water feeding regulation function enables immersion during cutting of the material

mobile cutting head on multiple bearings with rocker and integrated gas pressure shock absorber guarantees a precise cut

TECHNICAL INFORMATION

Motor:	2,2 kW / 230 V
Speed:	2800 min ⁻¹
Diameter:	350x25,4 mm
Cutting length:	1350 mm
Cutting depth:	110 mm
Weight:	150 kg
Dimensions:	1750x800x1400 mm

ITEM NUMBER	DESCRIPTION	LIST PRICE RRP (IN EURO WITHOUT VAT)
370073	UTS 630 INCL. 1x GX13 Silencio Ø350	

+
accessories available!
 p. 118

ADVANTAGES



Plug-in water pump for quick exchange without tools.



Elegant and practical cable carrier and hose routing.



Mitre function up to 45°. The material always remains horizontally fixed on the cutting table. A 100% view of the material is provided, thereby ensuring optimum precision.

VARIANTS

ITEM NUMBER	DESCRIPTION	MOTOR	SPEED (MIN ⁻¹)	BLADE SIZE (MM)	CUTTING DEPTH (MM)	CUTTING LENGTH (MM)	LIST PRICE RRP (IN EURO WITHOUT VAT)
370164	UTS 630 INCL. 1x GX13 Silencio Ø350	2,6kW/230V	2800	Ø350	110	1350	
370165	UTS 630 INCL. 1x GX13 Silencio Ø350	3kW/400V	2800	Ø350	110	1350	
370167	UTS 630 INCL. 1x GX13 Silencio Ø450	3kW/400V	2800	Ø450	150	1350	
370166	UTS 630 INCL. 1x GX13 Silencio Ø450	2,2kW/230V/4P	1400	Ø450	140	1350	

RECOMMENDED BLADES



GX13 SILENCIO see page 52



SHOXX KSX see page 54



SHOXX KX13 SILENCIO s. page 57

UTS 630/DZR

SPEED-REGULATED INCL. DIA-SCHEIBE



PRECISE + UNIQUE!

VERSATILE **HIGHEND TABLE SAW** FOR TILERS AND NATURAL STONE PROCESSORS. INCL. 1 DIAMOND BLADE FOR PRECISE CUTTING AND CHAMFERING OF SLABS IN ONE OPERATION.

water feeding regulation function enables immersion during cutting of the material

mobile cutting head on multiple bearings with rocker and integrated gas pressure shock absorber guarantees a precise cut

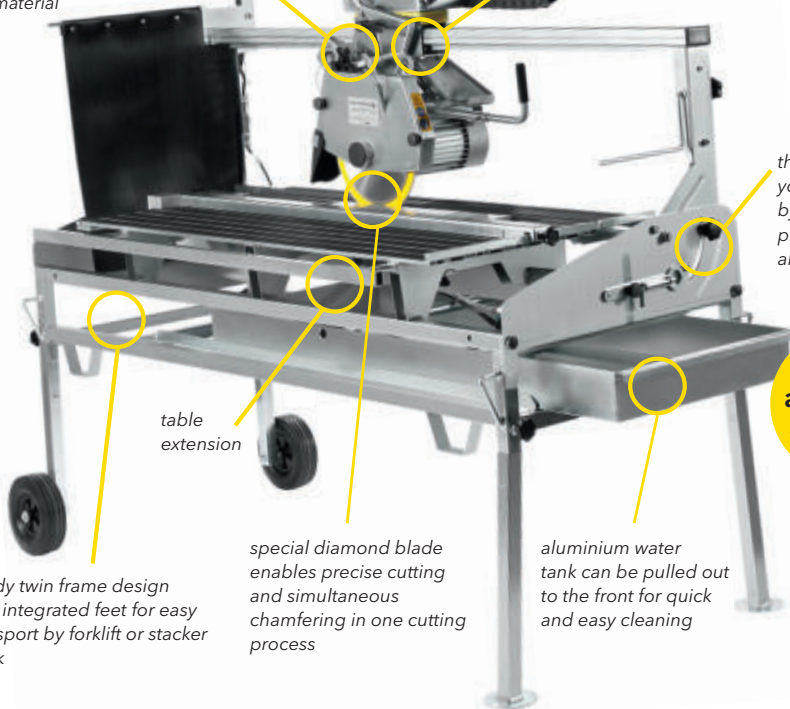

the tilting of the yoke is supported by two sturdy gas pressure shock absorbers

+
accessories available!
p. 118

sturdy twin frame design with integrated feet for easy transport by forklift or stacker truck

table extension

special diamond blade enables precise cutting and simultaneous chamfering in one cutting process

aluminium water tank can be pulled out to the front for quick and easy cleaning

ADVANTAGES

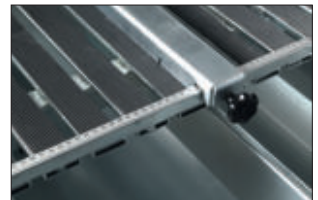

Rubberised table top, so that the material is ideally and securely supported. Precise measuring scale (also on the opposite side), so that accurate longitudinal cuts can be implemented.



For cutting and chamfering slabs in one operation.



The material always remains horizontally fixed on the cutting table. A 100% view of the material is provided, thereby ensuring optimum precision.



Speed regulation for optimisation of the cutting quality.



Plug-in water pump for quick exchange without tools.

TECHNICAL INFORMATION

Motor:	2,2 kW / 230 V
Speed:	2200-3450 min ⁻¹
Diameter:	300x25,4 mm
Cutting length:	1300 mm
Cutting depth:	85 mm
Weight:	155 kg
Dimensions:	1850x850x1520 mm

ITEM NUMBER	DESCRIPTION	LIST PRICE RRP (IN EURO WITHOUT VAT)
370072	UTS 630 DZR incl. 1x diamond blade Ø300/Ø250	

RECOMMENDED BLADES



SHOXX KSX see page 54

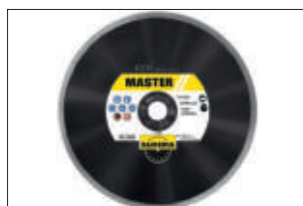

MASTER KCM see page 55

+ chamfering blades Ø250mm left/right

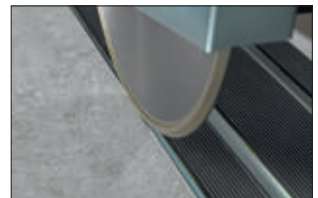

Polishing chamfers + edges

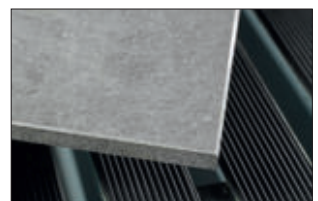

The result:
Clean finish on a worktop.

UTS 520/DZR

SPEED-REGULATED INCL. **GX13 SILENCIO**



DIE **HIGHEND TABLE SAW** FOR LANDSCAPE GARDENERS IDEAL FOR PROCESSING FINE STONEWARE, GRANITE & LARGE-FORMAT PAVING SLABS.

ADVANTAGES



Speed regulation for optimisation of the cutting quality.



Rubberised table top, so that the material is ideally and securely supported. Precise measuring scale (also on the opposite side), so that accurate longitudinal cuts can be implemented.



Plug-in water pump for quick exchange without tools.



Aluminium water tank can be pulled out to the front for quick and easy cleaning.



CUTTING

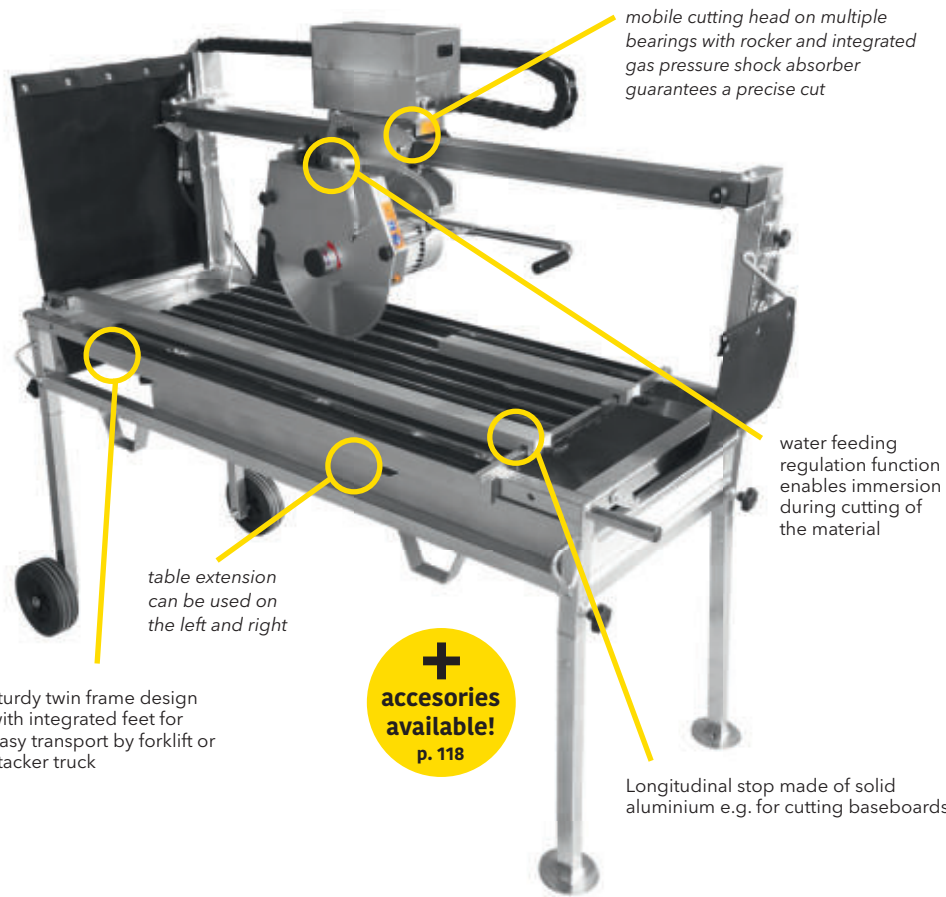

mobile cutting head on multiple bearings with rocker and integrated gas pressure shock absorber guarantees a precise cut

water feeding regulation function enables immersion during cutting of the material

table extension can be used on the left and right

sturdy twin frame design with integrated feet for easy transport by forklift or stacker truck

+
accessories available!
p. 118

Longitudinal stop made of solid aluminium e.g. for cutting baseboards

TECHNICAL INFORMATION

Motor:	2,2 kW / 230 V
Speed:	2200-3450 min ⁻¹
Diameter:	350x25,4 mm
Cutting length:	1200 mm
Cutting depth:	110 mm
Weight:	110 kg
Dimensions:	1535x820x1400 mm

DETAILS

- 3-part machine consisting of: Machine base frame with cutting unit and plug-in feet; removable support table; removable aluminium water tray
- Torsion-resistant, solid double frame design for maximum stability
- Clean finished, retractable handles as well as crane hooks for transport

ITEM NUMBER	DESCRIPTION	LIST PRICE RRP (IN EURO WITHOUT VAT)
370071	UTS 520 DZR INCL.1x diamond blade Ø350	

RECOMMENDED BLADES



SHOXX GX13 SILENCIO s. page 52



SHOXX KSX s. page 54



SHOXX KX13 SILENCIO s. page 57

TTS 520

INCL. KCM



PREMIUM **TILE CUTTER** FOR LARGE-FORMAT FINE STONEWARE AND NATURAL STONE SLABS UP TO A MAX. THICKNESS OF 30 MM.



+
accessories
available!
p. 118

water feeding regulation function enables immersion during cutting of the material

mobile cutting head on multiple bearings with rocker and integrated gas pressure shock absorber guarantees a precise cut

side table not included

ADVANTAGES



Folding supports enable easy transport and set-up of the machine.



The table extension allows large slabs to be processed safely.



Plug-in water pump for quick exchange without tools.



45 degree cuts from the right-hand side. The optional side table can easily be fixed on the left and right without tools.



Longitudinal stop made of solid aluminium suitable for the protected recessed scale.

DETAILS

- 3-part machine consisting of: Machine base frame with cutting unit and fold-away feet; removable support table; removable aluminium water tray
- Solid bar handles and crane hooks for transport
- Quick clamping lever for simple set up

TECHNICAL INFORMATION

Motor:	2,2 kW / 230 V
Speed:	2800 min ⁻¹
Diameter:	250x25,4 mm
Cutting length:	1500 mm
Cutting depth:	62 mm
Weight:	108 kg
Dimensions:	1880x580x1410 mm

ITEM NUMBER	DESCRIPTION	LIST PRICE RRP (IN EURO WITHOUT VAT)
370068	TTS 520 INCL. 1x KCM Ø250	

RECOMMENDED BLADES



SHOXX KSX see page 54



MASTER KCM see page 55

TTS 500

INCL. KCM

MADE IN EUROPE



PREMIUM TILE CUTTER FOR FINE STONEWARE & NATURAL STONE SLABS UP TO A MAX. THICKNESS OF 30 MM.



CUTTING

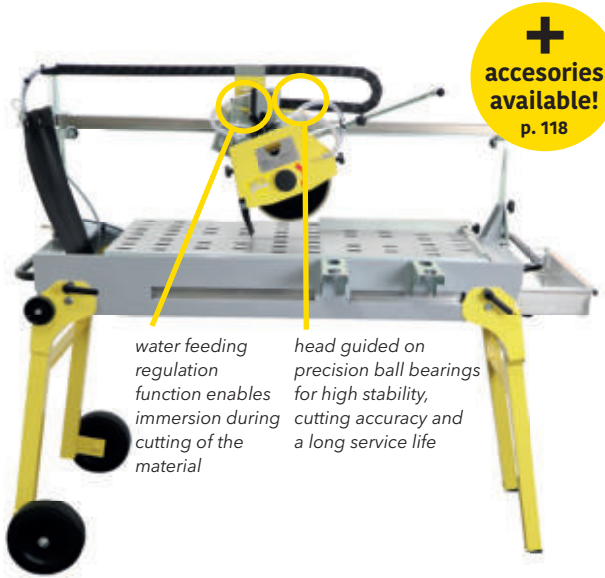

+
accessories available!
p. 118

water feeding regulation function enables immersion during cutting of the material

head guided on precision ball bearings for high stability, cutting accuracy and a long service life

DETAILS

- 3-part machine consisting of: Machine base frame with cutting unit and fold-away feet; removable support table;
- removable aluminium water tray
- Solid bar handle for transport

TECHNICAL INFORMATION

Motor:	2,2 kW / 230 V
Speed:	2800
Durchmesser:	230x25,4 mm
Cutting length max.:	1000 mm
Cutting depth max.:	60 mm
Weight:	59 kg
Maße:	1270x580x1210 mm

ITEM NUMBER	DESCRIPTION	LIST PRICE RRP (IN EURO WITHOUT VAT)
370065	TTS 500 INCL.1x KCM Ø230	

ADVANTAGES



Extendable aluminium water tank for quick and easy cleaning.

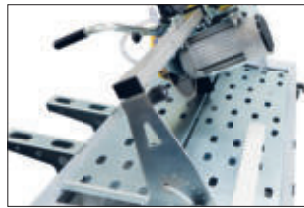

45 degree cuts from the right-hand side. The optional side table can easily be fixed on the left and right without tools.



Longitudinal stop made of solid aluminium suitable for the recessed scale.



Side table available as an accessory. Can be fixed to the right or left of the frame.



Plug-in water pump for quick exchange without tools.



Integrated gas pressure shock absorber guarantees a precise cut.



Precise measuring scale (also on the opposite side), so that accurate longitudinal cuts can be implemented. The scaling remains permanently visible due to the low-lying dimensions.



Folding supports enable easy transport and set-up of the machine.

RECOMMENDED BLADES



MASTER KCM see page 55



SHOXX KSX see page 54

ACCESSORIES

FOR TABLE SAWS | TILE CUTTERS

POS.	ITEM NUMBER	DESCRIPTION											LIST PRICE RRP (IN EURO WITHOUT VAT)			
			CTS-800 830 AMP/HIBIA	CTS-500	STM 3.50	CTS-650	FB 650/700	UTS-520	UTS-500	UTS-420	UTS-630	TTS-520		TTS-500		
	370628	Angle stop 0 - 180°	✓	✓		✓		✓	✓	✓	✓	✓	✓	✓		
	370090	Operating hours counter*	✓	✓		✓		✓	✓		✓	✓	✓	✓		
	370436	Laser battery operation*	✓	✓				✓	✓		✓					
	370284	Special grip for rolling table machines	✓	✓		✓										
	370070	Side table 530 x 600 mm									✓		✓	✓		
6	370766	Flexitable 500-76							✓							
7	370767	Flexitable 500-115						✓								
	370479	Longitudinal stop 1040 mm						✓			✓	✓	✓	✓		
	370483	Longitudinal stop for rolling table		✓		✓										
	370147	Longitudinal 1350 mm										✓	✓			
	370482	Longitudinal 450 mm					✓	✓	✓	✓	✓	✓	✓	✓		
	390403	Longitudinal UTS														
	370642	Longitudinal stop for rolling table	✓													
	390331	Longitudinal TTS														
	370185	Water pump S1 with connector	✓	✓		✓		✓	✓	✓	✓	✓	✓	✓	✓	
	370203	Water pump large with connector					✓									
	370240	Water pump universal without connector	✓	✓	✓	✓		✓	✓	✓	✓	✓	✓	✓	✓	
	390286	Sharpening stone	✓	✓	✓	✓	✓	✓	✓	✓	✓	✓	✓	✓	✓	
	370609	Replacement pouch set (for cyclone filter (PU 25 pcs.)	✓													
	370643	Cutting channel	✓													
	370670	cyclone filter	✓													

* Price incl. assembly. Only available for new machines.

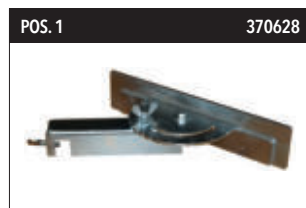

Angle stop 0 - 180°



Operating hours counter

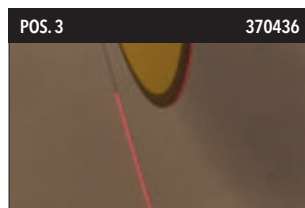

Laser Batteriebetrieb



Special grip f. rolling table machines



Side table



Flexitable



Longitudinal stop



Longitudinal stop

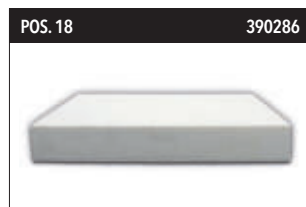

Sharpening stone

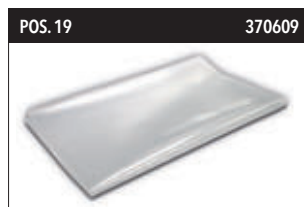

Replacement pouch set f. cyclone filter
LxW: 600x300 mm, 150µ; PU 25 St.



Cutting channel



cyclone filter



**FIND THE RIGHT TOOL
FOR YOUR PROJECT!**

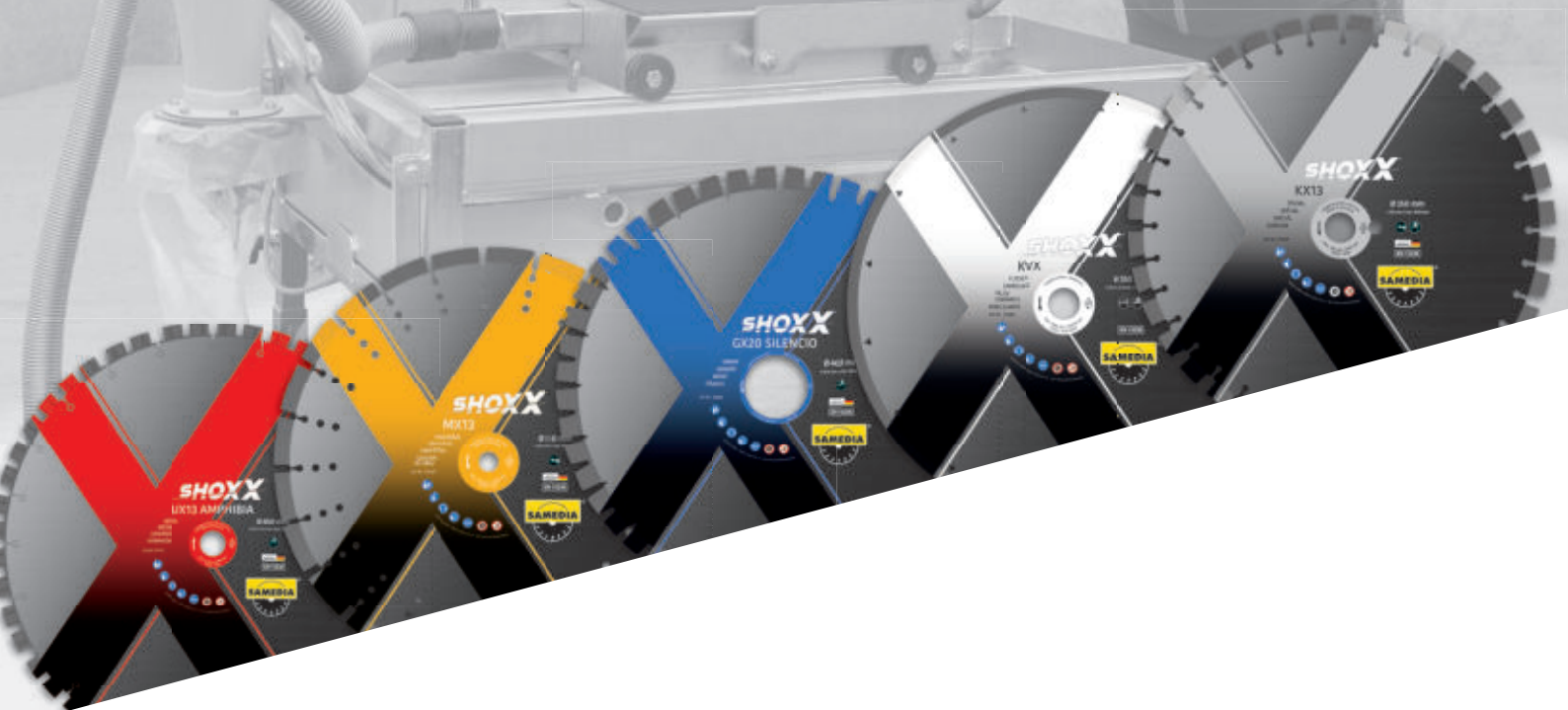

PROFESSIONAL DIAMOND TOOLS & MACHINES FOR TABLE SAWS AND TILECUTTERS

incl. recommendation table
from page 47

www.samedia.com

FSB 500



FLOOR SAW FOR CONCRETE AND ASPHALT.



DETAILS

AREA OF APPLICATION

- Road repairs in concrete or asphalt.
- Cutting work in pipe trenches for pipe laying.
- Installation of expansion joints in concrete floors.
- Cutting channels for contact loops or cable laying.

SPECIAL FEATURES

- Maximum cut = 185 mm when using a 500 mm blade
- Simple parking brake function for high safety.
- Solid frame / chassis
- Low vibration
- Easy maintenance of the cutting shaft bearings
- Water tank made of steel, 35 l

TECHNICAL INFORMATION

Motor:	Honda GX 390 Petrol
kW / HP:	9,6 / 13
Diameter:	350 / 450 / 500 x 25,4 mm
Cutting depth:	125 / 175 / 185 mm
Weight:	135 kg

ITEM NUMBER	DESCRIPTION	LIST PRICE RRP (IN EURO WITHOUT VAT)
370100	FSB 500	

RECOMMENDED BLADES



SHOXX AX13 see page 60

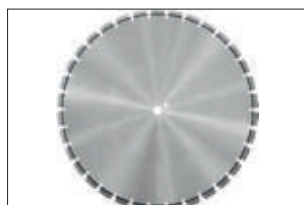

MASTER BFM see page 59



CORING/DRILLING

BSS 180



COMPACT + UNIVERSAL!

COMPACT, UNIVERSAL **CORING SYSTEM**
FOR HAND-HELD USE OR USE WITH A DRILL STAND
FOR WET AND DRY DRILLING.



DETAILS

- Drill stand can be pivoted continuously up to 45°
- Drilling motor supplied in a carrying case
- Clamping collar Ø 60 mm (RAPID LOCK KBZ 300)
- Total weight (kg): 17.6 (BMF 180 6.0 kg; BSP 220 11.6 kg)

TECHNICAL INFORMATION BMF 180

Motor:	2,2 kW / 230 V
Speed:	510 / 1030 min ⁻¹
Torque:	27,5 / 14,9 Nm
Diameter:	225 mm
Weight:	6,0 kg

DRILLING RANGE

	BRICKWORK	CONCRETE
FREEHAND	32-225 mm	32-132 mm*
STATIONARY	32-202 mm	32-182 mm

* stand recommended from 80 mm

PROFESSIONAL SET

ITEM NUMBER	DESCRIPTION	LIST PRICE RRP (IN EURO WITHOUT VAT)
380501	BSS 180 Coring system	

* price without core bit

SET COMPONENTS



1x Carrying case



1x BMF 180 Coring machine
2-speed (also suitable for freehand coring/drilling)



1x BSP 220 Core drill stand



BSS 200

MADE IN EUROPE



INTEGRATED DUST EXTRACTION!

COMPACT, UNIVERSAL **CORING SYSTEM** FOR HAND-HELD USE OR USE WITH A DRILL STAND. WITH CHANGE ADAPTER FOR EASY CHANGE-OVER FROM WET DRILLING TO DRY DRILLING WITH DUST EXTRACTION.



DETAILS

- Clamping collar Ø 60 mm (RAPID LOCK KBZ 300)
- Drill stand can be pivoted continuously up to 45°
- Total weight (kg): 18.9 (BMF 200 7.3 kg; BSP 220 11.6 kg)
- Incl. quick coupling for dust extraction for dry drilling
- Incl. quick coupling for water connection
- Drilling motor supplied in a carrying case

TECHNICAL INFORMATION BMF 200

Motor:	2,2 kW / 230 V
Speed:	750 / 1080 / 2500 min ⁻¹
Torque:	28,8 / 12,0 / 8,6 Nm
Diameter:	202 / 252 mm
Weight:	7,3 kg

DRILLING RANGE

	BRICKWORK	CONCRETE
FREEHAND	20-252 mm	20-132 mm*
STATIONARY	20-202 mm	20-202 mm

* stand recommended from 80 mm

PROFESSIONAL SET

ITEM NUMBER	DESCRIPTION	LIST PRICE RRP (IN EURO WITHOUT VAT)
380925	BSS 200 Coring system	

* price without core bit

SET COMPONENTS



1x Carrying case



1x BMF 200 Coring machine 3-speed (incl. water and suction connection + adapter)



1x BSP 220 Core drill stand (incl. KBZ 300)



CORING/DRILLING

BSS 210



HIGH PERFORMANCE!

CORING SYSTEM

FOR HAND-HELD USE OR USE WITH A DRILL STAND
FOR WET AND DRY DRILLING.



DETAILS

- MASTERTRONIC - multifunction electronics with overload protection and soft start
- Safety sliding clutch with PRCD circuit br
- With change adapter for easy changeover from wet drilling to dry drilling with dust extraction
- Safety sliding clutch with PRCD circuit breaker
- Core bit connection with double spindle 1 1/4" UNC plus R 1/2" (can also be used for simultaneous centring)
- Quick-coupling connection for the water supply or dust extraction, incl. adapter
- Clamping collar 60 mm

TECHNICAL INFORMATION BMF 200

Motor:	2,2 kW / 230 V
Speed:	750 / 1080 / 2500 min ⁻¹
Torque:	28,8 / 12,0 / 8,6 Nm
Diameter:	202 / 252 mm
Weight:	7,3 kg

DRILLING RANGE

	BRICKWORK	CONCRETE
FREEHAND	20-252 mm	20-132 mm*
STATIONARY	20-202 mm	20-202 mm

* stand recommended from 80 mm

+
Accessories available!
p. 135

PROFESSIONAL SET

ITEM NUMBER	DESCRIPTION	LIST PRICE RRP (IN EURO WITHOUT VAT)
380955	BSS 210 Coring system	

SET COMPONENTS



1x Carrying case



1x BMF 200 core drilling motor 3-speed (also suitable for freehand drilling)



1x BSP 220 core drill stand



1x DBK Ø82x450
1x DBK Ø102x450

BST 220



POWERFUL!

DIAMOND DRY DRILL SET WITH SOFT IMPACT FUNCTION
FOR HAND-HELD USE OR USE WITH A DRILL STAND
FOR DRILLING IN CONCRETE.



DETAILS

- Powerful 2-speed drilling machine
- Multifunction electronics with overload protection and soft start
- LED display for the optimal feed
- Switchable soft impact for use in concrete
- Safety slip clutch
- Drill spindle for holding 1/2" and 1 1/4" drill bits
- incl. center point + dust adapter
- Clamping collar 60 mm

TECHNICAL INFORMATION BMT 220

Motor:	2,15 kW / 230 V
Speed:	725 / 1.500 min ⁻¹
Torque:	57 Nm / 27 Nm
Diameter:	80-200 mm / 42-80 mm
Weight:	6,5 kg

DRILLING RANGE

	BRICKWORK	CONCRETE
FREEHAND	50-160 mm	50-160 mm
STATIONARY	50-200 mm	50-200 mm

PROFESSIONAL SET

ITEM NUMBER	DESCRIPTION	LIST PRICE RRP (IN EURO WITHOUT VAT)
380985	BST 220 Diamond dry drill set	

+
Accessories available!
p. 135

SET COMPONENTS



1x Carrying case



1x BMT 220 core drilling motor
2-speed (also suitable for freehand drilling)



1x BSP 220 core drill stand



1x DBD 82x300
1x DBD 102x300



CORING/DRILLING

BSS 220



HIGH PERFORMANCE!

COMPACT CORING SYSTEM USE OR USE WITH A DRILL STAND.
FOR WET AND DRY DRILLING. INCLUDING 3-SPEED CORE DRILLING MOTOR.



DETAILS

- Quick-change system for motor (RAPID LOCK KBZ 350), 4-hole
- Drill stand can be pivoted continuously up to 45°
- Total weight (kg): 18.9 (BMS 220 7.3 kg; BSP 222 11.6 kg)

TECHNICAL INFORMATION BMS 220

Motor:	2,2 kW / 230 V
Speed:	350 / 920 / 1280 min ⁻¹
Torque:	40,1 / 16,7 / 12,0 Nm
Diameter:	220 / 320 mm
Weight:	7,3 kg

DRILLING RANGE

	BRICKWORK	CONCRETE
STATIONARY	20-220 mm	20-220 mm

PROFESSIONAL SET

ITEM NUMBER	DESCRIPTION	LIST PRICE RRP (IN EURO WITHOUT VAT)
380502	BSS 220 Coring system	

* price without core bit

SET COMPONENTS



1x BMS 220 core drilling motor
3-speed



1x BSP 222 Core drill stand
(incl. KBZ 350)



BSS 300



FOR LARGE DIAMETERS!

PROFESSIONAL CORING SYSTEM

FOR WET AND DRY DRILLING. INCLUDING 2-SPEED CORE DRILLING MOTOR.



DETAILS

- Quick-change system for motor (RAPID LOCK KBZ 310), 6-hole
- Idle speed (rpm): 490/1160
- Drill stand can be pivoted continuously up to 45°
- Total weight (kg): 32.6 (BMS 300 13 kg; BSP 300 19.6 kg)

TECHNICAL INFORMATION BMS 300

Motor:	3,4 kW / 230 V
Speed:	190 / 390 min ⁻¹
Torque:	157 / 75 Nm
Diameter:	350 mm
Weight:	13,0 kg

DRILLING RANGE

	BRICKWORK	CONCRETE
STATIONARY	60-300 mm	60-300 mm

PROFESSIONAL SET

ITEM NUMBER	DESCRIPTION	LIST PRICE RRP (IN EURO WITHOUT VAT)
380656	BSS 300 Coring system	

* price without core bit

SET COMPONENTS



1x BMS 300 core drilling motor
2-speed



1x BSP 300 Core drill stand



CORING/DRILLING

BSS 350

MADE IN EUROPE



FOR VERY LARGE DIAMETERS!

PROFESSIONAL **CORING SYSTEM** WITH POWERFUL 3-SPEED CORE DRILLING MOTOR FOR WET AND DRY DRILLING.



DETAILS

- Quick-change system for motor (RAPID LOCK KBZ 310), 6-hole
- Idle speed (rpm): 330/750/1390
- Total weight (kg): 33.6 (BMS 350 14 kg; BSP 300 19.6 kg)

TECHNICAL INFORMATION BMS 350

Motor:	3,0 kW / 230 V
Speed:	220 / 500 / 935
Torque:	99 / 43 / 21
Diameter:	350 mm
Weight:	14,0 kg

DRILLING RANGE

	BRICKWORK	CONCRETE
STATIONARY	32-350 mm	32-350 mm

PROFESSIONAL SET

ITEM NUMBER	DESCRIPTION	LIST PRICE RRP (IN EURO WITHOUT VAT)
380873	BSS 350 Coring system	

* price without core bit

SET COMPONENTS



1x BMS 350 core drilling motor 3-speed



1x Core drill stand BSP 300 (RAPID LOCK)



1x Spacer plate, 45mm, 6 holes



BMF 160

MADE IN EUROPE



FREEHAND 1-SPEED CORE DRILLING MACHINE – IDEAL FOR DRY DRILLING



+
Accessories available!
p. 135

DETAILS

- Can be used for wet and dry drilling
- MASTERTRONIC - multifunction electronics with overload protection and soft start
- Safety sliding clutch with PRCD circuit breaker
- Core bit connection with double spindle 1 1/4" UNC plus R 1/2" (can also be used for simultaneous centring)
- Quick-coupling connection for the water supply
- Clamping collar 60 mm
- In a practical carrying case

DRILLING RANGE

	BRICKWORK	CONCRETE
FREEHAND	62-162 mm	62-112 mm*
STATIONARY	62-162 mm	62-132 mm

* stand recommended from 80 mm

TECHNICAL INFORMATION

Motor:	1,8 kW / 230 V
Speed:	550 min ⁻¹
Torque:	23,3 Nm
Diameter:	165 mm
Weight:	4,6 kg

ITEM NUMBER	DESCRIPTION	LIST PRICE RRP (IN EURO WITHOUT VAT)
390088	BMF 160 Core drilling machine	

INCLUSIVE



Carrying case



Spanner size 32

BMF 180

MADE IN EUROPE



STURDY UNIVERSAL 2-SPEED CORE DRILLING MACHINE FOR UNIVERSAL FREEHAND AND STATIONARY USE.



+
Accessories available!
p. 135

DETAILS

- Can be used for wet and dry drilling
- MASTERTRONIC - multifunction electronics with overload protection and soft start
- Safety sliding clutch with PRCD circuit breaker
- Core bit connection with double spindle 1 1/4" UNC plus R 1/2" (can also be used for simultaneous centring)
- Quick-coupling connection for the water supply
- Clamping collar 60 mm
- In a practical carrying case

DRILLING RANGE

	BRICKWORK	CONCRETE
FREEHAND	32-225 mm	32-132 mm*
STATIONARY	32-202 mm	32-182 mm

* stand recommended from 80 mm

TECHNICAL INFORMATION

Motor:	2,2 kW / 230 V
Speed:	510 / 1030 min ⁻¹
Torque:	27,5 / 14,9 Nm
Diameter:	225 mm
Weight:	6,0 kg

ITEM NUMBER	DESCRIPTION	LIST PRICE RRP (IN EURO WITHOUT VAT)
390047	BMF 180 Core drilling machine	

INCLUSIVE



Carrying case



Spanner size 32



CORING/DRILLING

BMF 200

MADE IN
EUROPE



HIGH-PERFORMANCE UNIVERSAL 3-SPEED **CORE DRILLING MACHINE** – FOR FREEHAND AND STATIONARY USE. FOR WET AND DRY DRILLING.



+
Accessories
available!
p. 135

DETAILS

- MASTERTRONIC - multifunction electronics with overload protection and soft start
- With change adapter for easy changeover from wet drilling to dry drilling with dust extraction
- Safety sliding clutch with PRCD circuit breaker
- Core bit connection with double spindle 1 1/4" UNC plus R 1/2" (can also be used for simultaneous centring)
- Quick-coupling connections for the water supply or dust extraction, incl. adapter
- Clamping collar 60 mm

TECHNICAL INFORMATION

Motor:	2,2 kW / 230 V
Speed:	750 / 1080 / 2500 min ⁻¹
Torque:	28,8 / 12,0 / 8,6 Nm
Diameter:	202 / 252 mm
Weight:	7,3 kg

DRILLING RANGE

	BRICKWORK	CONCRETE
FREEHAND	20-252 mm	20-132 mm*
STATIONARY	20-202 mm	20-202 mm

* stand recommended from 80 mm

ITEM NUMBER	DESCRIPTION	LIST PRICE RRP (IN EURO WITHOUT VAT)
370450	BMF 200 Core drilling machine	

INCLUSIVE



Carrying case



Water and suction cup connection



adapter



adapter

BMS 220

MADE IN EUROPE



LIGHTWEIGHT 3-SPEED CORE DRILLING MACHINE – FOR STATIONARY USE.



DETAILS

- MASTERTRONIC - multifunction electronics with overload protection and soft start
- Safety sliding clutch with PRCD circuit breaker
- Core bit connection with double spindle 1 1/4" UNC & R 1/2"
- Quick-coupling connection for the water supply
- Changeover plate with standard hole pattern

DRILLING RANGE

	BRICKWORK	CONCRETE
STATIONARY	20-220 mm	20-220 mm

TECHNICAL INFORMATION

Motor:	2,2 kW / 230 V
Speed:	350 / 920 / 1280 min ⁻¹
Torque:	40,1 / 16,7 / 12,0 Nm
Diameter:	220 / 320 mm
Weight:	7,3 kg

ITEM NUMBER	DESCRIPTION	LIST PRICE RRP (IN EURO WITHOUT VAT)
390048	BMS 220 Core drilling machine	

+
Accessories available!
p. 135

BMS 300

MADE IN EUROPE



STURDY 2-SPEED CORE DRILLING MACHINE - FOR STATIONARY USE.



DETAILS

- MASTERTRONIC - multifunction electronics with overload protection and soft start
- Safety sliding clutch with PRCD circuit breaker
- Core bit connection with double spindle 1 1/4" UNC plus R 1/2"
- Quick-coupling connection for the water supply
- Changeover plate with standard hole pattern

DRILLING RANGE

	BRICKWORK	CONCRETE
STATIONARY	60-300 mm	60-300 mm

TECHNICAL INFORMATION

Motor:	3,4 kW / 230 V
Speed:	190 / 390 min ⁻¹
Torque:	157 / 75 Nm
Diameter:	350 mm
Weight:	13,0 kg

ITEM NUMBER	DESCRIPTION	LIST PRICE RRP (IN EURO WITHOUT VAT)
390203	BMS 300 Core drilling machine	

+
Accessories available!
p. 135



BMS 350

MADE IN EUROPE



STURDY 3-SPEED CORE DRILLING MACHINE – FOR STATIONARY USE.



+
Accessories
available!
p. 135

DRILLING RANGE

	BRICKWORK	CONCRETE
STATIONARY	32-350 mm	32-350 mm

DETAILS

- MASTERTRONIC - multifunction electronics with overload protection and soft start
- Safety sliding clutch with PRCD circuit breaker
- Core bit connection with double spindle 1 1/4" UNC plus R 1/2"
- Quick-coupling connection for the water supply

TECHNICAL INFORMATION

Motor:	3,0 kW / 230 V
Speed:	220 / 500 / 935
Torque:	99 / 43 / 21
Diameter:	350 mm
Weight:	14,0 kg

ITEM NUMBER	DESCRIPTION	LIST PRICE RRP (IN EURO WITHOUT VAT)
370102	BMS 350 Core drilling machine	

BMT 220

NEW!

MADE IN EUROPE



POWERFUL 2-SPEED DRILLING MACHINE – FOR FREEHAND AND STATIONARY USE.



+
Accessories
available!
p. 135

DRILLING RANGE

	BRICKWORK	CONCRETE
FREEHAND	50-160 mm	50-160 mm
STATIONARY	50-200 mm	50-200 mm

DETAILS

- Multifunction electronics with overload protection and soft start
- LED display for the optimal feed
- Switchable soft impact for use in concrete
- Safety slip clutch
- Drill spindle for holding 1/2" and 1 1/4" drill bits
- incl. transport case
- incl. center point + dust adapter
- Clamping neck 60 mm

TECHNICAL INFORMATION

Motor:	2,15 kW / 230 V
Speed:	725 / 1.500 min ⁻¹
Torque:	57 Nm / 27 Nm
Diameter:	80-200 mm / 42-80 mm
Weight:	6,5 kg

ITEM NUMBER	DESCRIPTION	LIST PRICE RRP (IN EURO WITHOUT VAT)
380992	BMT 220 core drilling motor dry drilling with transport case	

BSP 220 / BSP 222

MADE IN EUROPE



COMPACT CORE DRILL STAND – AVAILABLE IN 2 VERSIONS.



Fig. BSP 220

DETAILS

- Can be pivoted continuously up to 45°
- Clamping collar 60 mm with Quick-clamping device RAPID LOCK (BSP 220)
- Motor changeover plate with quick-clamping device RAPID LOCK (BSP 222)
- Height and side spirit level integrated in the feed slide
- Drilling depth scale
- Magnetic feed lever - also fits on all screwed connections on the drill stand
- Centring aid for spot drilling
- Lightweight and precise as a result of high-strength aluminium design
- Incl. set of spanners
- Wheel set available as an accessory

TECHNICAL INFORMATION

Drilling range:	bis 220 mm
Useable core bit length:	bis 500 mm
Weight:	11,6 kg
Hub:	580 mm

VARIANTS

ITEM NUMBER	DESCRIPTION	KBZ 300 (390061)	CLAMPING COLLAR 60MM RAPID LOCK	KBZ 350 (390062)	MOUNTING PLATE FOR DRILLING MOTOR RAPID LOCK	LIST PRICE RRP (IN EURO WITHOUT VAT)
390058	BSP 220	✓	✓			
370455	BSP 222			✓	✓	

INCLUSIVE



BSP 220: Clamping collar 60mm with quick-clamping device RAPID LOCK (KBZ 300).



BSP 222: mounting plate for drilling motor, 4-hole, with quick-clamping device RAPID LOCK (KBZ 350).



BSP 300

MADE IN
EUROPE



STURDY CORE DRILL STAND



DETAILS

- Can be pivoted continuously up to 45°
- Motor changeover plate with quick-clamping device (RAPID LOCK KBZ 310)
- Height and side spirit level integrated in the feed slide
- Drilling depth scale
- Magnetic feed lever - also fits on all screwed connections on the drill stand
- Centring aid for spot drilling
- Solid steel design, base plate made of aluminium
- Wheels for easy transport
- Incl. set of spanners

TECHNICAL INFORMATION

Drilling range: until 300 mm

Useable core bit length: until 600 mm

Weight: 19,6 kg

Hub: 700 mm

ITEM NUMBER	DESCRIPTION	LIST PRICE RRP (IN EURO WITHOUT VAT)
390204	BSP 300 Core drill stand	

INCLUSIVE



Mounting plate for drilling motor, 6-hole, with quick-clamping device RAPID LOCK (KBZ 390).

ACCESSORIES

FOR CORING SYSTEMS/MACHINES

POS.	ITEM NUMBER	BEZEICHNUNG	DESCRIPTION	LIST PRICE RRP (IN EURO WITHOUT VAT)
1	390277	KBZ 610	Concrete fixing set	
2	390278	KBZ 630	Expanding elements (PU 25 pc.) for KBZ 610 (Pos. 1)	
3	390155	KBZ 670	RAWL anchor shell for masonry M12, for KBZ 690 (Pos. 4)	
4	370702	KBZ 690	Masonry fixing set	
5	390154	KBZ 620	Impact anchor M12i Ø16 mm (PU 25 pc.) for KBZ 690 (Pos. 4)	
6	390254	-	Setting tool for impact anchor M12 for KBZ 620 (Pos. 5)	
7	390063	KBZ 400	Centring rod for freehand drilling, 350-450mm, L, R 1/2	
8	370517	KBZ 410	Centring rod for freehand coring/drilling, Ø19 mm, for BMF 200 (370450)	
9	390033	KBZ 750	core bit extension 300 mm, 1 1/4"	
10	390195	KBZ 770	core bit extension Alu, 200 mm, 1 1/4"	
11	390259	KBZ 800	Vacuum pump	
12	390258	KBZ 850	Universal vacuum plate for drill stands BSP 220 (390058) u. BSP 300 (390204)	
13	390065	KBZ 500	Dust extraction rotor for dry drilling	
14	390059	KBZ 250	Water recovery ring Ø 250	
15	390060	KBZ 150	Water recovery ring Ø 150	
16	370474	-	Replacement rubber part Ø 250 for KBZ 250 (Pos. 14)	
17	370475	-	Replacement rubber part Ø 150 for KBZ 150 (Pos. 15)	
18	390069	KBZ 700	PWT S, Water pressure tank 10 l	
19	390266	KBZ 720	PWT P, Water pressure tank 10 l	
20	390061	KBZ 300	Clamping collar 60 mm RAPID LOCK	
21	390084	KBZ 310	Spacer plate, diameter 45mm, 6-hole for BSP 300 (390204)	
22	390085	KBZ 370	Spacer plate, diameter 20mm, 6-hole for BSP 300 (390204)	
23	390062	KBZ 350	Mounting plate 4-hole for BMS 220 (390048)	
24	370025	KBZ 390	Mounting plate 6-hole for BMS 220 (390048)	
25	370332	-	Wheel set for core drill stand BSP 200 (390058) + BSP 222 (370455)	
26	390064	KBZ 450	Quick-release ring EZ-FIT	
27	370712	-	Copper quick-release ring	
28	370457	-	Spanner SW 32 for core drilling machine	
29	370456	-	Spanner SW 24 for core bit 1/2"	
30	370458	-	Spanner SW 41 for core bit 1 1/4"	
31	390018	KBZ 320	adapter R1/2 i x 1 1/4 UNC i	
32	390162	KBZ 340	adapter R1/2 a x 1 1/4 UNC a	
33	390064	KBZ 450	Quick-release ring EZ-FIT	
34	390432	KBZ 365	adapter HILTI 1 1/4" female HILTI-DDBL	
35	390165	KBZ 380	adapter HILTI 1 1/4" female HILTI-DD BI	
36	390999	KBZ 900	Plastic case for core drilling unit	

Illustrations and further details see the following pages.



KBZ 610 Concrete fixing set
1 expanding element 16 SE
1 spindle bolt 16/50/160
1 washer
1 clamping nut



KBZ 630 Expanding elements for KBZ 610 (Pos. 1)
(PU 25 pc.)



KBZ 670 RAWL-anchor shell for masonry M12
suitable for fastening set KBZ 690 (Pos. 4)



KBZ 690 Masonry fixing set
consists of a threaded rod,
hexagon nut, washer



ACCESSORIES FOR CORING SYSTEMS/MACHINES



POS. 5 390154
KBZ 620 Impact anchor
M12i Ø16 mm (PU 25 pc.)
suitable for fixing set KBZ 690
(Pos. 4)

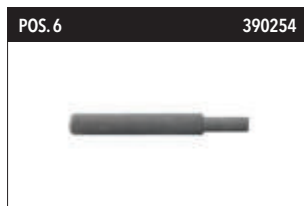

POS. 6 390254
Setting tool for impact anchor for KBZ 620 (Pos. 5)
M12



POS. 7 390063
KBZ 400 Centring rod for freehand drilling
or core bit lengths 350-450 mm, L, R 1/2"



POS. 8 370517
KBZ 410 Centring rod for freehand drilling
or core bit lengths 350-450 mm
(for core drilling machine BMF 200), Plug-in connection



POS. 9 390033
KBZ 750 core bit extension
300mm 1 1/4"

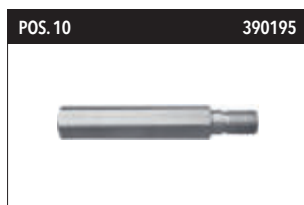

POS. 10 390195
KBZ 770 core bit extension
ALU, 200 mm 11/4"



POS. 11 390259
KBZ 800 Vacuum pump
0,12 kW; 4 m³ / h; 230 V



POS. 12 390258
KBZ 850 Universal vacuum plate for drill stands
BSP 220 (390058) and
BSP 300 (390204).

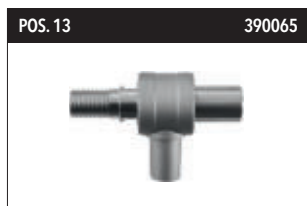

POS. 13 390065
KBZ 500 Dust extraction rotor for dry drilling
Precision all-metal construction for effective dust extraction during dry drilling. increases cutting speed and the service life of the core bit, prevents "jams".
Suitable for all 1 1/4" core bits.
Can be used with all commercially available industrial vacuum cleaners.



POS. 14 390059
KBZ 250 Water recovery ring Ø250
High-grade aluminium construction.
For the prevention of water damage with stationary wet drilling.
Suitable for drill stands BSP 220 (390058) and BSP 300 (390204).



POS. 15 390060
KBZ 150 Water recovery ring Ø150
High-grade aluminium construction.
For the prevention of water damage with stationary wet drilling.
Suitable for drill stands BSP 220 (390058) and BSP 300 (390204).



POS. 16 370474
Replacement rubber part Ø250
Suitable for Water recovery ring KBZ 250 (Pos.. 14).



POS. 17 370475
Replacement rubber part Ø150
Suitable for Water recovery ring KBZ 150 (Pos. 15)



POS. 18 390069
KBZ 700 PWT S Water pressure tank 10 l
High-quality construction with stainless steel tank + pressure valve.
For carrying out network-independent wet drilling. Water connection suitable for all SAMEDIA core drilling machines and quick-coupling (Gardena), hose connection 1/2".



POS. 19 390266
KBZ 720 PWT P Water pressure tank 10 l
Version with plastic tank.
For carrying out network-independent wet drilling. Water connection suitable for all SAMEDIA core drilling machines and quickcoupling (Gardena), hose connection 1/2".



POS. 20 390061
KBZ 300 Clamping collar 60 mm RAPID LOCK
Suitable for drill stands BSP 220 (390058) und BSP 300 (390204).

ACCESSORIES

FOR CORING SYSTEMS/MACHINES



KBZ 310 Spacer plate
45 mm, 6-hole
for expanding the core-Ø.
In conjunction with drill stand
BSP 300 (390204) for use of
core bits up to Ø 400.



KBZ 370 Spacer plate
20 mm, 6-hole
for expanding the core-Ø.
In conjunction with drill stand
BSP 300 (390204) for use of
core bits up to Ø 350.

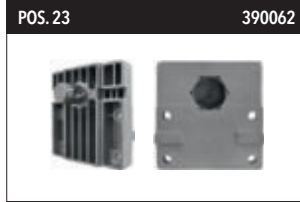

KBZ 350 mounting plate
4-hole RAPID LOCK
Quick-clamping device for
stationary core drilling machine
BMS 220 (390048).

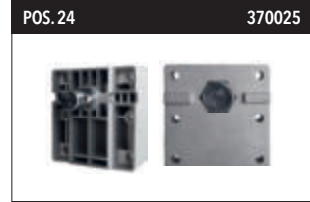

KBZ 390 mounting plate
6-hole RAPID LOCK
Quick-clamping device for
stationary core drilling machine
BMS 220 (390048).



Wheel set
for core drill stands
BSP 220 (390058) +
BSP 222 (370455).
For easy mounting
on the drill stand.



KBZ 450 Quick-release ring
EZ-FIT
Enables the drill bit to be
professionally removed from
the drill spindle.
Suitable for all 1 1/4" core bits.



Copper quick-release ring
Enables easy release of the
core bit from the drill spindle.
Suitable for all 1 1/4" core bits.



Spanner SW 32
for core drilling machine

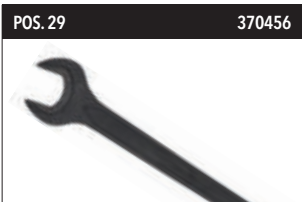

Spanner
SW 24 for core bit 1/2"
For releasing the core bits.



Spanner
SW 41 for core bit 1 1/4"
For releasing the core bits.



KBZ 320 adapter
R1/2 i x 1 1/4 UNC i



KBZ 340 adapter
R1/2 a x 1 1/4 UNC a



KBZ 360 adapter Hilti
1 1/4" female
HILTI-DD BU (outer star)



KBZ 365 adapter Hilti
1 1/4" female
HILTI-DDBL (inner star)



KBZ 380 adapter Hilti
1 1/4" female
HILTI-DD BI (3/6 grooves)



KBZ 900 Plastic case
for core drilling unit
with sturdy handles and
wheels, stackable, 2 safety
locks, 1000 x 400 x 470 mm,
16 kg



CORING/DRILLING

BMF 090

MADE IN
EUROPE



SOCKET SINKER FOR ELECTRICAL INSTALLATION.



DETAILS

- MASTERTRONIC - multifunction electronics with overload protection and soft start
- Safety sliding clutch
- Side handle with clamping collar 60 mm
- In a practical carrying case
- Drilling range (mm): 32-162

TECHNICAL INFORMATION

Motor:	2,2 kW / 230 V
Diameter:	162 mm
Weight:	4,8 kg

PROFESSIONAL SETS

ITEM NUMBER	DESCRIPTION	CARRYING CASE	ADAPTER M16 + CENTER DRILL	DAZ 100	LIST PRICE RRP (IN EURO WITHOUT VAT)
380878	BMF 090 Professional Set 1	✓	✓		
380879	BMF 090 Professional Set 2	✓	✓	✓	

INCLUSIVE



1x carrying case



1x adapter M16 and
1x centre drill

PROFESSIONAL SET 2 (ADDITIONALLY)



Set 380879 with 1x DAZ 100
dust collection unit (core bits not
included)



GRINDING

CGR 512

PROFESSIONAL SET OR SYSTEM SET INCL. ZA 5



LIGHT & STURDY!

GRINDING MACHINE Ø125 INCL. DIAMOND GRINDING WHEEL AND TANOS PLASTIC SYSTEMCASE



DETAILS

- Robust, high-torque grinding machine with high gear reduction and greatly reduced, adjustable speed
- Easy levelling of the grinding wheel using the flexible brush ring
- Keyless assembly of the plastic cover (quick lock)

TECHNICAL INFORMATION

Motor:	1,55 kW / 230 V
Speed (idling):	2.000-7.600 min ⁻¹
Torque:	5 Nm
Cable length:	4 m
Weight:	4,1 kg

PROFESSIONAL SETS

ITEM NUMBER	DESCRIPTION	CGR 512 INCL. CASE	HIGH-END-GRINDING WHEEL Z A5 Ø125	ADAPTER PLATE, DRIVE BAR + SUPPLEMENTARY SET	WET & DRY VAKUUM CLEANER VAC 520	LIST PRICE RRP (IN EURO WITHOUT VAT)
380977	CGR 512 Professional set	✓	✓			
380981	CGR 512 System set	✓	✓	✓	✓	

ADVANTAGES



Extraction hood can open, for flush grinding.



Speed controller in the handle.



Quick switch to lock the spindle.



Adjustable handle.

COMPONENTS PROFI-SET



1x grinding machine CGR 512



1x HighEnd diamond grinding wheel Z-A5 Ø125 (350005)
Use on screed, tile adhesive, concrete.



1x Tanos plastic systemcase (370624) for easy and safe transport.

COMPONENTS SYSTEM SET (ADDITIONALLY)



1x VAC 520 wet and dry vacuum cleaner* (370286). Also available as a single part. (s. p. 150).



1x Supplementary set (370494). Also available as a single part. (s. p. 151).



1x adapter plate EZ Fixpack for VAC 520 (370636). Also available as a single part. (s. p. 150).

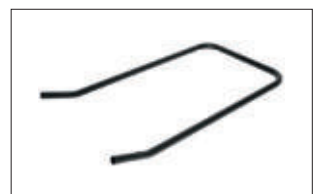

1x Drive bar B35 (370088). Also available as a single part. (s. p. 151).

CGR 515

PROFESSIONAL SET INCL. ZA 5



STURDY GRINDING MACHINE Ø125 INCL. DIAMOND GRINDING WHEEL AND TONAS PLASTIC SYSTEM CASE.



DETAILS

- Robust, high-torque grinding machine with high gear reduction and greatly reduced, adjustable speed
- Wear-free extraction hood with automatic height adjustment: no levelling of the grinding wheel and replacement of the brush rim is no longer necessary!
- Incl. HighEnd-Grinding wheel Z-A5, 125 mm for universal on concrete and screed
- Fits completely in a sturdy plastic case
- Incl. adapter

TECHNICAL INFORMATION

Motor:	1,55 kW
Speed:	2.000-7.600 min ⁻¹
Torque:	5 Nm
Diameter:	125 mm
Cable length:	4 m
Weight:	4,1 kg

PROFESSIONAL SET

ITEM NUMBER	DESCRIPTION	LIST PRICE RRP (IN EURO WITHOUT VAT)
380956	CGR 515 incl. 1x diamond grinding wheel Z-A5 Ø125	

ADVANTAGES



Extraction hood can open, for flush grinding.



Adjustable handle.



Safe storage of the machine with up to 3 tools in a foam inlay.

SET COMPONENTS



1x carrying case



1x grinding machine CGR 515



1x HighEnd diamond grinding wheel ZA 5 Ø125 (350005)



1x adapter for spiral suction hose



GRINDING

CGR 530

PROFESSIONAL SET INCL. ZA 5



POWERFUL GRINDING MACHINE Ø125 INCL. DIAMOND GRINDING WHEEL.



DETAILS

- Handy concrete grinder with the highest performance in its class
- Wear-free extraction hood with automatic height adjustment: no levelling of the grinding wheel and replacement of the brush rim is no longer necessary!
- Incl. Z-A5 HighEnd grinding wheel 125mm for universal use on concrete and screed
- Fits completely in a sturdy plastic case
- Incl. adapter

TECHNICAL INFORMATION

Motor:	1,9 kW
Speed:	8.200 min ⁻¹
Torque:	5 Nm
Diameter:	125 mm
Cable length:	4 m
Weight:	4,1 kg

PROFESSIONAL SET

ITEM NUMBER	DESCRIPTION	LIST PRICE RRP (IN EURO WITHOUT VAT)
380941	CGR 530 incl. 1x diamond grinding wheel Z-A5 Ø125	

ADVANTAGES



Extraction hood can open, for flush grinding.



Adjustable handle.



Safe storage of the machine with up to 3 tools in a foam inlay.

SET COMPONENTS



1x Transport case



1x grinding machine CGR 530



1x Premium diamond grinding wheel ZA 5 Ø125 (350005)



1x adapter for spiral suction hose

CGR 550

PROFESSIONAL SET OR SYSTEM SET INCL. ZA 5

NEW!



HIGH-PERFORMANCE!

GRINDING MACHINE Ø125 INCL. DIAMOND GRINDING WHEEL AND TONAS PLASTIC SYSTEM CASE.



DETAILS

- Handy concrete grinder with the highest performance in its class
- Easy levelling of the grinding wheel using the flexible brush ring
- Incl. Z-A5 HighEnd grinding wheel 125mm for universal use on concrete and screed
- Fits completely in a sturdy plastic case
- Keyless assembly of the plastic cover (quick lock)

TECHNICAL INFORMATION

Motor:	1,9 kW
Speed:	8.200 min ⁻¹
Torque:	5 Nm
Diameter:	125 mm
Cable length:	4 m
Weight:	4,1 kg

PROFESSIONAL SETS

ITEM NUMBER	DESCRIPTION	CGR 512 INCL. CASE	HIGH-END-GRINDING WHEEL Z A5 Ø125	ADAPTER PLATE, DRIVE BAR + SUPPLEMENTARY SET	WET & DRY VAKUUM CLEANER VAC 520	LIST PRICE RRP (IN EURO WITHOUT VAT)
370722	CGR 550 Professional set	✓	✓			
380990	CGR 550 System-Set	✓	✓	✓	✓	

ADVANTAGES



Safe storage of the machine in a foam inlay.



Quick switch to lock the spindle.



Stable plastic hood with an easy-to-open segment for flush grinding.



Adjustable handle.

COMPONENTS PROFI-SET



1x grinding machine CGR 550



1x Tanos plastic systemcase (370624) for easy and safe transport.



1x Premium diamond grinding wheel ZA 5 Ø125 (350005 - Use on screed, tile adhesive, concrete.

COMPONENTS SYSTEM SET (ADDITIONALLY)



1x VAC 520 wet and dry vacuum cleaner* (370286). Also available as a single part. (s. p. 150).



1x Supplementary set (370494). Also available as a single part. (s. p. 151).



1x Adapterplatte EZ Fixpack für VAC 520 (370636). Also available as a single part (s. p. 151).

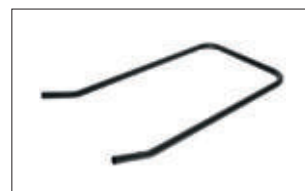

1x Drive bar B35 (370088). Also available as a single part. (s. p. 151).



GRINDING

CGR 125

PROFESSIONAL SET INCL. **UBX**

COMPACT GRINDING MACHINE Ø125 INCL. DIAMOND GRINDING WHEEL.



DETAILS

- For Ø125mm grinding wheel
- Powerful 2200 W motor with electronic speed control, soft start and overload protection
- COMPACT & ERGONOMIC DESIGN
- Protective hood can be opened for grinding to the edge
- Anti-vibration handles
- 2-row brush rim for effective dust extraction and optimum support
- Built-in turbine for improved dust extraction
- Supplied in a handy case

TECHNICAL INFORMATION

Motor:	2,2 kW / 220-240 V / 50-60 Hz
Speed:	4.500-9.500 min ⁻¹
Diameter:	125 mm
Weight:	5,75 kg

PROFESSIONAL SET

ITEM NUMBER	DESCRIPTION	LIST PRICE RRP (IN EURO WITHOUT VAT)
380846	CGR 125 incl. 1x diamond grinding wheel UBX Ø125	

ADVANTAGES



Extraction hood can open, for flush grinding.



Robust double anti-vibration handle for optimal guidance and control.



2-row brush ring for effective dust extraction and optimum support.

SET COMPONENTS



1x carrying case



1x grinding machine CGR 125



1x Premium diamond grinding wheel UBX Ø125 (350036)

CGR 180

PROFESSIONAL SET INCL. **UBX**

COMPACT GRINDING MACHINE Ø180 INCL. DIAMOND GRINDING WHEEL.



DETAILS

- for Ø180mm grinding wheel
- Powerful 2200 W motor with electronic speed control, soft start and overload protection
- COMPACT & ERGONOMIC DESIGN
- Protective hood can be opened for grinding to the edge
- Anti-vibration handles
- Weight without mains cable (kg): 5.74
- Supplied in a handy case

TECHNICAL INFORMATION

Motor:	2,2 kW / 220-240 V / 50-60 Hz
Speed:	3.200-6.500 min ⁻¹
Diameter:	180 mm
Weight:	5,74 kg

PROFESSIONAL SET

ITEM NUMBER	DESCRIPTION	LIST PRICE RRP (IN EURO WITHOUT VAT)
380848	CGR 180 incl. 1x diamond grinding wheel UBX Ø 180	

ADVANTAGES



Extraction hood can open, for flush grinding.



Robust double anti-vibration handle for optimal guidance and control.



Easy setting of the speed.

SET COMPONENTS



1x carrying case



1x grinding machine CGR 180



1x Premium diamond grinding wheel UBX Ø180 (350038)



GRINDING

FGR 500

**SWISS
MADE**

PROFESSIONEL **FLOOR GRINDER**: SMALL, LIGHT AND HANDY.
FOR FLOORING REFURBISHMENT.



ITEM NUMBER	DESCRIPTION	LIST PRICE RRP (IN EURO WITHOUT VAT)
370229	FGR 500	
370243	Additional weight 10 kg steel	
370244	Dust belt	

SET COMPONENTS (not included)



Additional weight 10 kg (370243)



Dust belt (370244)

DETAILS

- Brushless motor
- High-torque drive through belt transmission
- Maximum grinding performance guaranteed; 1 m² in 2 min
- Incl. operating hours counter
- Thermal motor protection switch
- Soft-start electronics
- Separate cooling fan for the motor
- Compact cable coil
- Elastically dampened grinding wheel fixture for perfect smooth running
- Magnetic holder facilitates tool changing
- Carefully designed handling; ergonomic foldable machine guidance handle
- Compact design for easy transport and operation
- Optimally balanced weight distribution
- Practical levelling of the grinding wheel with a spirit level and single lever
- Sturdy velcro strap for optimum adjustment of the dust extraction
- Efficient double-tube dust extraction
- Grinding to the edge < 1 cm from the wall
- Large, smooth-running rubber wheels Ø200 mm
- Ideal for areas from 5 - 100 m²

TECHNICAL INFORMATION

Power:	2.600 W
Voltage:	230 V
Speed:	2.200 min ⁻¹
Large grinding wheels:	Ø 300x22,23 mm
Cable length:	10 m
Vibration loading:	0,27 m ²
Noise level:	59 dB
Weight:	35 kg

SUITABLE VACUUM CLEANERS FGR 500



VAC 650 (370246) s. page 152.

ADVANTAGES



Easy to transport thanks to the compact design.



Lightweight & compact for easy transport and operation (35 kg).



Tool-free grinding wheel - fixture with magnetic holder.



Flexibly mounted drive shaft.



Easy machine setup via inclination mechanism + dragonfly.



Adjustable, flexible Velcro dust strap.



Attachable additional weight 10 kg.



Hour meter on the side.



GRINDING

SUITABLE GRINDING WHEELS FGR 500

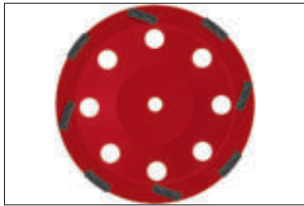

MASTER SBM (350111) s. p. 95.

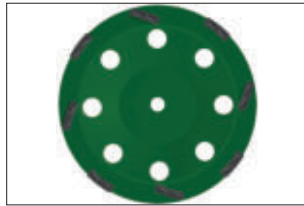

MASTER SBX (350119) s. p. 95.

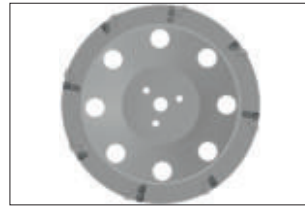

MASTER PKR (350115) s. p. 96.

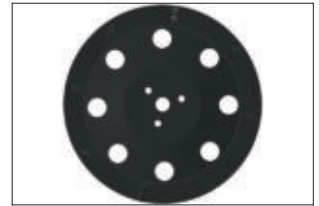

MASTER PKD (350113) s. S. 96.



MASTER PCD (350114) s. p. 97.

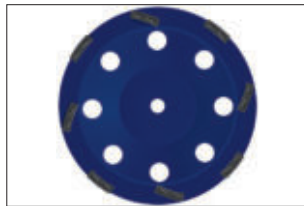

MASTER SBA (350118) s. p. 96.

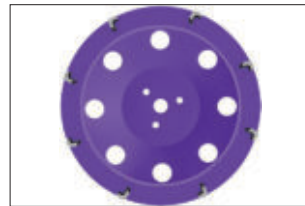

MASTER RAP (350112) s. p. 97.

EN 13236
compliant



RECOMMENDATION TABLE FLOOR GRINDERS

MATERIAL	TILE ADHESIVE/SCREED					CONCRETE/ADHESIVE/UNIV.				SPECIAL		
	SBM	SBX	PKR	PKD	PCD	SBM	SBX	SBA	PKR	PKD	PCD	RAP
	MASTER	MASTER	MASTER	MASTER	MASTER	MASTER	MASTER	MASTER	MASTER	MASTER	MASTER	MASTER
Material removal	FINE-MIDDLE	FINE-MIDDLE	MIDDLE-STRONG	STRONG	MIDDLE-STRONG	FINE-STRONG	FINE-STRONG	MIDDLE-STRONG	MIDDLE-STRONG	STRONG	MIDDLE-STRONG	FINE
Illustration												
cement-based tile adhesive	✓✓	✓✓	✓✓	✓✓	✓✓	✓✓	✓✓		✓✓	✓✓	✓✓	
cement-based Flex tile adhesive	✓✓	✓✓	✓✓	✓✓	✓✓	✓✓	✓✓		✓✓	✓✓	✓✓	
dispersion tile adhesive			✓✓	✓✓	✓✓				✓✓	✓✓	✓✓	
synthetic resin tile adhesive			✓✓	✓✓	✓✓				✓✓	✓✓	✓✓	
screed	✓	✓✓	✓	✓		✓	✓✓	✓✓	✓	✓		
screed abrasive		✓✓	✓	✓			✓✓	✓✓	✓	✓		
bitumen screed			✓✓	✓✓	✓✓				✓✓	✓✓	✓✓	
concrete	✓✓	✓	✓			✓✓	✓		✓			✓✓
concrete abrasive	✓	✓✓	✓			✓	✓✓	✓✓	✓			✓✓
granite	✓					✓						
adhesive residues			✓✓	✓	✓✓				✓✓	✓	✓✓	
carpet residues			✓✓	✓	✓✓				✓✓	✓	✓✓	
coatings	✓	✓	✓✓	✓✓	✓✓	✓	✓		✓✓	✓✓	✓✓	✓✓
paints	✓	✓	✓	✓	✓	✓	✓		✓	✓	✓	✓✓
bitumen (only < 15° C)			✓✓	✓	✓✓				✓✓	✓	✓✓	
epoxy resin			✓	✓✓	✓				✓	✓✓	✓	

✓ = well suited ✓✓ = Ideally suited

THE RIGHT CHOICE

of the diamond cup wheels depends from the surface and affects the desired grinding result. It will help to achieve the optimal expected result.



VAC 520



COMPACT & HIGH-PERFORMANCE!

PROFESSIONAL **WET AND DRY VACUUM CLEANER** – PERFECT AS A CONSTRUCTION SITE VACUUM CLEANER IN COMBINATION WITH ELECTRICAL TOOLS.



DETAILS

- Perfect in combination with electrical tools
- Appliance socket with automatic switch-on
- With permanent electromagnetic pulse filter cleaning without interruption of the suction flow
- Selection switch for volume flow/hose diameter
- Vacuum power adjustable depending on the hose diameter
- Acoustic signal for negative deviation of the volume flow
- Rotary shutter for using the PE emptying bag
- Closure for suction connection
- Soft start controller and after-running electronics
- Water level detection with sensor switch-off
- Incl. graduated connection sleeve; 2 polyester folded filter cartridges, 3 PE emptying bags
- Incl. antistatic suction hose, length: 5 m

TECHNICAL INFORMATION

Power:	1.600 W
Voltage:	220-230 V
Suction inlet:	Ø 35 mm
Hose length:	5 m
Capacity:	35 l
Air-flow rate:	150 m³/h
Negative pressure:	230 mbar
Filter load:	120 m³/m²/h
Cable length:	8 m
Weight:	15,7 kg

ITEM NUMBER	DESCRIPTION	LIST PRICE RRP (IN EURO WITHOUT VAT)
370286	VAC 520 wet and dry vacuum cleaner	

INCLUSIVE



1x antistatic suction hose, length 5 m



2x polyester folded filter cartridges



1x connection sleeve



3x PE emptying bags



ACCESSORIES

FOR VAC 520

POS.	ITEM NUMBER	DESCRIPTION	LIST PRICE RRP (IN EURO WITHOUT VAT)
1	370133	Antistatic suction hose, Ø35 x 5m, AS 350-500	
2	390306	Suction and brush set for electrical tools	
3	370494	Supplementary set	
4	370088	Drive bar B35	
5	390304	Fleece filter bags FBV 25-35, double-layer, pack of 5	
6	390263	PE emptying bags FBPE 25/35, pack of 5	
7	370087	PE emptying bags H Asbestos, pack of 5	
8	390260	Folded filter cartridge FKP 4300, Class M, 2-pack	
9	370089	Folded filter cartridge FKP 4300, Class HEPA-Asbest, 2-pack	
10	370624	EZ-Pack systemcase (can be used with adapter plate/Pos. 11)	
11	370636	Adapter plate EZ-Fixpack for Tanos systemcase (Pos. 10)	
12	390664	Adapter for spiral suction hose, Ø49/39 mm	



Antistatic suction hose
Ø35 x 5m / AS 350-500



Suction and brush set for electrical tools
1x hand tube ED, 2x suction tube ED 50 cm, 1x dust nozzle 37 cm, 1x crevice nozzle 22 cm



Supplementary set
1x floor nozzle, plastic, 2x suction pipes (plastic, je 50 cm), 1x handle tube (plastic) with air leak slider

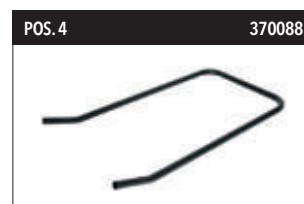

Drive bar
B35



Fleece filter bags
FBV 25-35, double-layer, pack of 5



PE-Entleerbeutel
FBPE 25/35 (390263), H-Asbest (370087), each in a pack of 5



Folded filter cartridge
FKP 4300 Class M (390260), FKP 4300, Class HEPA-Asbest (370089), each in a pack of 2



EZ-Pack systemcase
an be used with adapter plate (Pos. 11)



Adapter plate EZ-Fixpack
for Tanos systemcase (Pos. 10)



Adapter for spiral suction hose
Ø49/39 mm
Suitable for CGR 515/530 and BMF 200 core drilling machine.



VACUUMING

VAC 650

2-MOTOR HIGH-PERFORMANCE VACUUM CLEANER.

MADE IN EUROPE



DETAILS

- By-pass motors with integrated cooling
- Highly efficient standard filter cartridges
- Fine dust class M (H14 filter optional)
- Incl. suction and brush set
- Antistatic suction hose
- Integrated filter cleaning system
- Complete steel construction
- Suitable accessories available

TECHNICAL INFORMATION

Power:	2 x 1.150 W
Voltage:	230 V
Suction inlet:	Ø 50 mm
Capacity:	20 l
Air-flow rate:	360 m³/h
Filter surface area:	30.000-360 cm²-mm
Filter load:	120 m³/m²/h
Weight:	35 kg

INCLUSIVE



Suction and brush set.



ITEM NUMBER	DESCRIPTION	LIST PRICE RRP (IN EURO WITHOUT VAT)
370246	VAC 650 Industrial vacuum cleaners	

VAC 100

PORTABLE & LIGHTWEIGHT COMPACT VACUUM CLEANER.

MADE IN EUROPE



Use of the drill dust adapter

DETAILS

- Large filter cartridge, no dust bags required sucks and blows
- Ideal for cleaning the work place, Extraction during drilling, and customer service work in heating and sanitary areas
- The flexible plastic material attaches itself to the wall and also adheres to textured surfaces
- For all suction hose holders from Ø25mm
- Incl. BSA drilling dust adapter
- Incl. accessories: crevice nozzle, round brush, carrying strap

TECHNICAL INFORMATION

Power:	1.200 W
Voltage:	220-240 V
Suction inlet:	Ø 35 mm
Capacity:	6 l
Weight:	4 kg

SET COMPONENTS (not included)



Filter cartridge (390394):
LxBxH: 130x140x160 mm



BSA drilling dust adapter (390413):
For extracting drilling dust for all tile and masonry drills up to Ø24mm

ITEM NUMBER	DESCRIPTION	LIST PRICE RRP (IN EURO WITHOUT VAT)
390334	VAC 100 Compact vacuum cleaner	
390394	Filter cartridge	
390413	BSA drilling dust adapter	



ACCESSORIES FOR VAC 650

POS.	ITEM NUMBER	DESCRIPTION	LIST PRICE RRP IN € O. MWST.
1	370432	Adapter sleeve, conical, rubber, outer Ø50/37 mm, 200mm	
2	390697	HighEnd pipe and brush set, Ø38 mm	
3	390695	Microfine dust filter cartridge, class H14	
4	370264	Filter cartridge standard M	
5	390698	Stop valve	
6	370334	Waste sack PVC, antistatic, 80 µ (for retaining ring./Pos. 7)	
7	370335	Retaining ring for waste sack (Pos. 6)	
8	370382	Antistatic hose, 5m, incl. connection sleeves	



Adapter sleeve conical

Gummi; outer Ø 50/37 mm;
200 mm length
Ideal for connection CGR 125-220 bzw. CGR 180-220.



HighEnd pipe and brush set

Ø 38 mm
With quick lock for easy handling and a long service life.



Microfine dust filter cartridge

Class H14
For additional exhaust air purification.



Filter cartridge standard M

Class M, uncoated



Stop valve

Stop valve for interruption of the air flow for filter cleaning (without the disassembling the hose or holding it closed).



Waste sack

PVC, antistatic, 80 µ, TÜV tested
For retaining ring (Pos. 7).

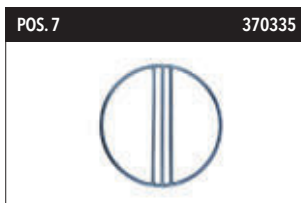

Haltering

Use with wast sack (Pos. 6) for dust-free disposal.



Antistatic hose

Ø 50 mm; 5 m length, DN40
Incl. connection sleeves 50/50 mm bzw. 50/37 mm.

DPS 650

DUST PRE-SEPARATOR WITH CYCLONE

NEW!

MADE IN EUROPE



DETAILS

- For integration between machine and deduster. Ideally suited in combination with the VAC 650.
- Filters the main part of the dust and thus protects the filter system of the deduster.
- Quick and easy emptying thanks to the quick-release fasteners on the container.
- Stands on four secure swivel castors.

TECHNICAL INFORMATION

Capacity	60 l
Suction inlet:	50 mm
Hose length:	3 m
Weight:	17 kg
Dimensions:	54 x 54x 113 cm

ITEM NUMBER	DESCRIPTION	LIST PRICE RRP (IN EURO WITHOUT VAT)
370832	DPS 650 Dust pre-separator with cyclone	



VACUUMING

PRODUCT-SUBSCRIPT

AGR 500 Professional set	102	CTS 650	108	GX13 SILENCIO SHOXX for angle grinders	24
ASM MASTER for floor grinders	61	CTS 800 830 AMPHIBIA®	104	GX20 SILENCIO SHOXX	
ASM MASTER for cut-off petrol saws	43	DAM MASTER	79	for table saws/tile cutters	52
ASTTECHNIC for floor grinders	61	DAX SHOXX	78	HLK MASTER for angle grinders	35
AST TECHNIC for cut-off petrol saws	43	DBD MASTER	75	HSP MASTER	100
AX13 SHOXX for floor grinders	60	DBH MASTER	76	KCM MASTER	
AX13 SHOXX for cut-off petrol saws	42	DBK 3-HOLES MASTER	74	for table saws/tile cutters	55
BCS SOLID for angle grinders	19	DBK MASTER	73	KCM MASTER for angle grinders	29
BFM MASTER for floor grinders	59	DBK-S MASTER	74	KCS SOLID for angle grinders	31
BGM MASTER for floor grinders	59	DBR MASTER	76	KCT TECHNIC for tile cutters	56
BGM MASTER for cut-off petrol saws	40	DBS-L MASTER	77	KCT TECHNIC for angle grinders	30
BGM MASTER for table saws/tile cutters	49	DBT/DBZ SHOXX	84	KJM MASTER	
BGM MASTER for angle grinders	18	DBT-E TECHNIC	85	for table saws/tile cutters	56
BMF 090	138	DBT-SET SHOXX	84	KJM MASTER for angle grinders	29
BMF 160	129	DBV-E SETS TECHNIC	83	KSX SHOXX	
BMF 180	129	DBV-E TECHNIC	82	for table saws/tile cutters	54
BMF 200	130	DBV-SETS SHOXX	82	KTM MASTER for angle grinders	28
BMS 220	131	DBV SHOXX	81	KTT TECHNIC for angle grinders	30
BMS 300	131	DBX SHOXX	72	KTX SHOXX for angle grinders	27
BMS 350	132	DFG MASTER	98	KVX SHOXX for table saws/tile cutters	55
BMT 220	132	DPS 650 Cyclone Separator - NEW!	153	KVX SHOXX for angle grinders	28
BSE MASTER for cut-off petrol saws	41	DSE SOLID	80	KX13 SHOXX for cut-off petrol saws	44
BSE MASTER for angle grinders	18	DSM MASTER	79	KX13 SHOXX for table saws/tile cutters	57
BSP 220 / BSP 222	133	DST TECHNIC	79	KX13 SHOXX for angle grinders	33
BSP 300	134	DSZ/DAZ Accessories	80	KX13 Silencio SHOXX	
BSS 180 Professional set	122	DZB MASTER	85	for table saws/tile cutters	57
BSS 200 Professional set	123	ECS 500	103	KX13 Silencio SHOXX for angle grinders	32
BSS 210 Professional set	124	FB 700	109	MES TECHNIC for wallchaser	66
BSS 220 Professional set	126	FGR 500	146	MES TECHNIC for angle grinders	22
BSS 300 Professional set	127	FQM/FQX/FQA MASTER for floor grinders	63	MSE MASTER for wallchaser	65
BSS 350 Professional set	128	FSA MASTER for floor grinders	63	MSE TECHNIC for angle grinders	22
BST 220 Professional set	125	FSA MASTER for cut-off petrol saws	46	MSS SOLID for angle grinders	22
BX13 SHOXX for floor grinders	58	FSB 500	120	MST-B / MST-L/F / MST-P MASTER	
BX13 SHOXX for cut-off petrol saws	40	FSM MASTER for floor grinders	62	for wallchaser	67
BX13 SHOXX for table saws/tile cutters	49	FSM MASTER for cut-off petrol saws	46	MST for table saws/tile cutters	51
BX13 SHOXX for angle grinders	17	GAV TECHNIC for angle grinders	37	MST MASTER for wallchaser	65
BX13 SILENCIO SHOXX		GKM MASTER for angle grinders	26	MST MASTER for cut-off petrol saws	41
for table saws/tile cutters - NEW!	49	GSM SILENCIO MASTER		MST MASTER for angle grinders	21
C E5 SHOXX for grinding machine freehand	93	for table saws/tile cutters	53	MTS SOLID for angle grinders	23
CGR 125 Professional set	144	GSM SILENCIO MASTER for angle grinders	25	MIT-LF/MIT-P/MIT-L MASTER for assembly cutter	67
CGR 180 Professional set	145	GTM MASTER for table saws/tile cutters	53	MIT MASTER for wallchaser	65
CGR 512 Professional set/System set	140	GTM MASTER for angle grinders	26	MIT MASTER for angle grinders	21
CGR 515 Professional set	141	GX13 SHOXX for table saws/tile cutters	52	MX13 MSF SHOXX for wallchaser	64
CGR 530 Professional set	142	GX13 SHOXX for angle grinders	25	MX13 SHOXX for floor grinders	59
CGR 550 Professional set/System set	143	GX13 SILENCIO SHOXX		MX13 SHOXX for cut-off petrol saws	41
CTS 500	106	for table saws	52	MX13 SHOXX for table saws/tile cutters	51

MX13 SHOXX for angle grinders	20	TCS SOLID for angle grinders	30	UX17 SHOXX for floor grinders	58
PCD MASTER for floor grinder	97	TKE MASTER for angle grinders	36	UX17 SHOXX for cut-off petrol saws	39
PCD MASTER for grinding machine freehand	94	TKM MASTER for angle grinders	36	UX17 SHOXX for angle grinders	16
PKD MASTER for floor grinder	96	TPM MASTER for wallchaser	66	VAC 100	152
PKD MASTER for grinding machine freehand	93	TPM MASTER for angle grinders	23	VAC 520	150
PKR MASTER for floor grinder	96	TPT TECHNIC for wallchaser	66	VAC 520 Accessories	151
Professional Set tiler	31, 82, 98	TPT TECHNIC for angle grinders	23	VAC 650	152
PVM MASTER for angle grinders	34	TSM MASTER for angle grinders	26	VAC 650 Accessories	153
RAP MASTER for floor grinder	97	TTS 500	117	VAC 650 Accessories	153
RAP MASTER for grinding machine freehand	93	TTS 520	116	VAC 650 Accessories	153
RFM MASTER for floor grinders	62	TX13 SHOXX for floor grinders	62	VAC 650 Accessories	153
RFM MASTER for cut-off petrol saws	45	TX13 SHOXX for cut-off petrol saws	45	VFM MASTER for angle grinders	33
RFS MASTER SET for angle grinders	34	TX13 SHOXX for angle grinders	33	WBX SHOXX for wallsaws	68
RX13 SHOXX for cut-off petrol saws	38	UB13 SHOXX for table saws/tile cutters	50	WFX SHOXX for wallsaws	70
RX13 SHOXX for angle grinders	17	UBM MASTER for grinding machine freehand	91	WHM MASTER for wallsaws	70
SBA MASTER for floor grinder	96	UBX MASTER for grinding machine freehand	91	WLX SHOXX for wallsaws	69
SBM MASTER for floor grinder	95	UGM MASTER for angle grinders	35	WTX SHOXX for wallsaws	69
SBX MASTER for floor grinder	95	USM MASTER for table saws/tile cutters	50	XR20 SHOXX for cut-off petrol saws	40
SMT MASTER for angle grinders	37, 100	UTM MASTER for angle grinders	35	Z A5 SHOXX for grinding machine freehand	90
SPM MASTER	99	UTS 420	112	Z AH5 SHOXX for grinding machine freehand	92
SPT TECHNIC	99	UTS 500	110	Z F5 SHOXX for grinding machine freehand	92
SPZ Accessories	100	UTS 520	111	Z U5 SHOXX for grinding machine freehand	89
SSB MASTER	98	UTS 520/DZR	115	ACCESSORIES for coring machines	135
STB TECHNIC for grinding machine freehand	91	UTS 630	113	ACCESSORIES for table saws/tile cutters	118
STF TECHNIC for grinding machine freehand	94	UTS 630/DZR	114		
STG MASTER for grinding machine freehand	92	UVM MASTER for cut-off petrol saws	46		
STM 350	107	UVM MASTER for angle grinders	34		
STS SOLID for grinding machine freehand	94	UX13 Amphibia SHOXX for table saws/tile cutters	48		
STU MASTER for grinding machine freehand	90				

General Terms and Conditions of Sale, Delivery and Payment of SAMEDIA GMBH Germany

I. General terms and conditions

1. The following General Terms and Conditions of Sale, Delivery and Payment (hereinafter referred to as General Terms and Conditions) of Samedia GmbH Germany (hereinafter referred to as the Proprietor) shall apply exclusively to the entire business relationship (contracts, deliveries and other services), but shall be limited to customers who, for their part, act in the exercise of their commercial or self-employed professional activities when concluding the contract, as well as to legal entities under public law and to special funds under public law. The Proprietor's General Terms and Conditions shall also apply to all future business relations, even if they are not expressly agreed upon again. Any general terms and conditions of the customer deviating from these General Terms and Conditions shall not be recognised. Deviations from these General Terms and Conditions shall only be effective if confirmed in writing by the Proprietor.

II. Offer, conclusion of contract and contract documents

1. The Proprietor's offers are always subject to change without notice and may be revoked at any time as long as they have not yet been legally bindingly accepted.
2. The property rights and copyrights to cost estimates, drawings and other offer documents shall remain with the Proprietor, unless otherwise expressly agreed. The documents may only be made accessible to third parties with the prior consent of the Proprietor.
3. Minor changes or customary deviations of the services, which do not impair the intended use, are permissible, provided that they are reasonable for the customer taking into account the interests of the Proprietor.
4. Unless otherwise agreed, the written order confirmation of the Proprietor shall be decisive for the scope of delivery. Subsidiary agreements and amendments require the written confirmation of the Proprietor.

III. Prices, terms of payment

1. The prices stated in the order confirmation shall apply. Unless otherwise agreed, prices are quoted ex works plus statutory value-added tax. The customer shall bear the costs of packaging, dispatch and freight insurance taken out at the customer's request. Additional deliveries and services shall be invoiced separately.
2. In the case of deliveries abroad, the Proprietor is entitled to recalculate the Customer's VAT liability for the service or delivery resulting from a possible VAT offence by the Customer. The customer is obliged to pay this value-added tax.
3. All deliveries shall be paid to the Proprietor within 30 days of the invoice date, net and free of charge, unless otherwise agreed.
4. Bills of exchange and cheques shall be regarded as performance on account of performance, provided that we have agreed to this.
5. The customer may only set off such claims which are undisputed or have been legally established.
6. In the event of default in payment by the customer, default interest shall be charged at the statutory rate. The Proprietor is entitled at any time to prove and invoice a higher interest loss.
7. If a considerable deterioration in the customer's financial standing impairing the credit-worthiness occurs, or if the Proprietor becomes aware of such circumstances, the Proprietor may immediately declare all claims against the customer not subject to objection due and payable and assert a right of retention against all claims of the customer, also insofar as they are based on other contracts, or demand relocation services or the provision of securities.

IV. Delivery, Delay, Impossibility

1. Compliance with agreed delivery periods requires the timely receipt of all documents to be provided by the customer, necessary approvals and releases, in particular of plans, as well as compliance with the agreed terms of payment and other obligations by the customer. If this is not the case, the delivery period shall be extended accordingly. Delivery periods shall commence upon dispatch of the order confirmation. Partial deliveries shall be permissible to a reasonable extent and their separate invoicing shall be permitted.
2. The delivery period shall be deemed to have been complied with if the delivery item has left the Proprietor's works by the end of the delivery period or if readiness for dispatch has been notified.
3. In the event of a delay in performance by the Proprietor, the customer may withdraw from the contract after setting a reasonable deadline and its expiration. The customer may withdraw from the contract without setting a deadline if the entire performance becomes finally impossible for the Proprietor prior to the passing of risk. This shall also apply if, in the case of an order, the execution of part of the delivery becomes impossible and the customer has a justified interest in rejecting the partial delivery. The same shall apply in the event of the Proprietor's inability to perform.
4. In the event of unforeseen hindrances which are beyond the control of the Proprietor and which the Proprietor was unable to avert despite reasonable care under the circumstances of the case - irrespective of whether they occur at the Proprietor's or a sub-supplier's premises, e.g. delays in the delivery of essential raw materials, strikes, lock-outs, etc. - the Proprietor shall be entitled to extend the delivery period by the duration of the hindrance. The Proprietor shall notify the Customer of such circumstances without delay. If the delay in delivery lasts longer than two months, both parties to the contract shall be entitled to withdraw from the contract.
5. If the Proprietor is in default and if the customer suffers damage as a result which the customer can substantiate, the customer may demand a lump-sum compensation for default. It shall amount to 0.5% for each full week of the delay, but in total not more than 5% of the value of that part of the total delivery which cannot be used on time or in accordance with the contract as a result of the delay.
6. Claims for damages by the customer which exceed the limits specified in Clause 5 shall be excluded in all cases of delayed delivery, subject to the provisions in Section VIII. This shall also apply to claims for reimbursement of expenses by the customer pursuant to Section 284 of the BGB (German Civil Code).

V. Shipment and transfer of risk

1. The place of performance and fulfilment for the contractual obligations of the Proprietor shall be its place of business.
2. The goods shall be dispatched exclusively at the request of the customer. Unless otherwise agreed, the dispatch route and means shall be at the discretion of the Proprietor.
3. The risk of deterioration in performance and remuneration shall pass to the customer at the time when the goods are handed over by the Proprietor to the forwarder or carrier or other person or institution designated by the Proprietor to carry out the shipment, at the latest, however, after leaving the Proprietor's warehouse. If the goods are ready for dispatch and if dispatch or acceptance is delayed for reasons for which the customer is responsible, the risk shall pass to the customer upon receipt of notification that the goods are ready for dispatch.
4. The Proprietor shall only be liable for improper packaging in the event of gross negligence on the part of the Proprietor, as well as in the event of gross negligence on the part of its legal representative or agents.

5. Delivered items shall be accepted by the customer, even if they show insignificant defects.
6. In the event of damage to or loss of the goods during transport, an inventory shall be carried out immediately and the Proprietor informed accordingly. The customer must assert any claims arising from transport damage directly and immediately with the forwarding agent.

VI. Simple, prolonged and extended retention of title

1. The Proprietor reserves the title (reserved goods) to all goods delivered by it until payment of its total claim from the business relationship. This shall also apply if the price for certain deliveries of goods specified by the customer has been paid, as the reserved property serves as security for its balance claim. The customer shall treat the goods belonging to the Proprietor with care.
2. The preparation and processing of the reserved goods shall be carried out on behalf of the Proprietor as manufacturer, without this giving rise to any obligations for the Proprietor. If the customer combines, mixes, mixes or processes the reserved goods with other goods or reshapes them, the Proprietor shall acquire co-ownership of the new object in the ratio of the value of the reserved goods to the other combined, mixed, blended or processed objects. The customer shall hold the co-ownership in safe custody for the Proprietor.
3. The customer may only sell the reserved goods owned by the Proprietor in the ordinary course of business. Other acts of disposal, in particular pledging and transfer by way of security of the reserved goods are not permitted.
The customer hereby assigns to the Proprietor by way of security any claims (including VAT) arising from the resale or any other legal reason (insurance, tort) in respect of the reserved goods. The latter accepts the assignment. The customer remains entitled to collect the assigned claims in the ordinary course of business.
4. If the value of the security rights to which the Proprietor is entitled exceeds the amount of all secured claims by more than 20 %, the Proprietor shall be obliged to release or retransfer the excess security at the Customer's request.
5. The authorisation of the customer to sell the reserved goods as well as to process, transform, mix, combine and blend, furthermore to collect the assigned claims, shall lapse in the event of non-compliance with the terms of payment, in the event of unauthorised acts of disposal and also if insolvency proceedings have been applied for against the customer. In this case, the Proprietor shall be entitled to take possession of the reserved goods immediately. The taking back or assertion of the retention of title or the seizure of the reserved goods by the Proprietor shall not constitute a withdrawal from the contract unless the Proprietor expressly declares this.

6. In the event of access by third parties to the reserved goods, the customer shall draw attention to the Proprietor's ownership and inform the latter immediately.
7. **Notice of defects, warranty, liability, statute of limitations**
1. The customer must carefully inspect deliveries of the Proprietor on the basis of purchase or work delivery contracts for defects, shortfalls, etc. and report complaints in detail in writing, at the latest within two weeks after handover or delivery. If a defect that already exists at the time of delivery is only discovered later (concealed defect), this must be reported immediately and in writing after its discovery.
2. All those parts which turn out to be defective as a result of a circumstance prior to the transfer of risk shall be repaired or replaced free of defects free of charge at the discretion of the Proprietor, provided that these are not only insignificant defects. Replaced parts shall become the property of the Proprietor.
3. The customer shall give the Proprietor reasonable time and opportunity for the necessary repair or replacement; otherwise the Proprietor shall be released from liability for the resulting consequences.
4. The customer has the right to withdraw from the contract or to reduce the contract price within the framework of the statutory provisions. Any right exercised by the customer in this respect to choose between withdrawal and reduction shall be binding on the customer. If there is only an insignificant defect, the customer shall only be entitled to a reduction of the contract price. Further claims against the Proprietor and its agents shall be governed by Section VIII of these General Terms and Conditions.
5. In the event of a justified notice of defects, the customer's right of retention shall only be permissible in an appropriate and reasonable relationship between the defect and the contract price.
6. No liability shall be assumed for natural wear and tear or damage arising after transfer of risk as a result of faulty or negligent handling, excessive loading, etc. If the customer or a third party carries out improper repairs, the Proprietor shall not be liable for the resulting consequences. The same shall apply to changes made to the delivery item without the prior consent of the Proprietor.
7. All warranty claims of the customer shall become statute-barred after 12 months. The respective statutory periods shall apply to claims for compensation due to damage that has not occurred to the delivery item itself. These shall also apply to defects in a building or to delivery items which have been used for a building in accordance with their customary manner of use and which have caused its defectiveness.

8. **Compensation and liability**
1. Claims for compensation on the part of the customer, irrespective of the legal basis, in particular due to breaches of ancillary obligations or tort, are excluded unless otherwise stipulated in these General Terms and Conditions.
2. This shall not apply to damage resulting from injury to life, limb or health or to other damage insofar as it was caused by gross negligence on the part of the Proprietor, its legal representatives or agents. The exclusion of liability in accordance with Clause 1 shall also not apply if there is liability based on the Product Liability Act, a given assurance or guarantee or due to the breach of essential contractual obligations. Compensation for the breach of essential contractual obligations shall, however, be limited to the foreseeable damage typical for the contract, unless intent or gross negligence is involved. A change in the burden of proof to the disadvantage of the customer is not associated with the above provisions.
3. Clauses 1 and 2 shall apply mutatis mutandis to the customer's claims for reimbursement of expenses pursuant to Section 284 of the BGB (German Civil Code).

VIII. Compensation and liability

IX. **Place of jurisdiction and applicable law**
1. German law shall apply to these GTC and the entire legal relationship between the Proprietor and the customer. UN sales law (Vienna UN Convention of 11.04.1980) shall not apply. The German language is the language of negotiation and contract.
2. The place of jurisdiction shall be the domicile of the Proprietor.
3. Should individual contractual provisions be or become invalid in whole or in part, this shall affect neither the validity of the other provisions nor the validity of the contract.

(Last amended 05/2021)



**PROVEN
QUALITY -
NEW DESIGN**

**FASTER
STRONGER
SAFER**

Professional
diamond tools & machines

© SAMEDIA GMBH, revision 2023/03 | EN SMD Art-No. 391451

No liability for printing errors! Technical changes and errors excepted, illustrations may deviate from the original for reasons of presentation and are therefore non-binding!

Tel. +49 7666 93 26 - 0
Fax +49 7666 93 26 - 900
verkauf@samedia.com

Marie-Curie-Straße 10
79211 Denzlingen
GERMANY



EN 13236



GROUP

www.samedia.com